

2600T Series Pressure Transmitters

Model 264BS Differential for high static maximum working pressure up to 41MPa, 5945psi



- **Base accuracy : $\pm 0.075\%$**
- **Span limits**
 - 0.2 to 2000kPa; 0.8inH₂O to 290psi
- **Reliable sensing system coupled with very latest digital technologies**
 - provides large turn down ratio up to 100:1
- **Comprehensive sensor choice**
 - optimize in-use total performance and stability
- **5-year stability**
- **Consistent conformance to all requirements**
 - offers improvement in quality, delivery and service areas
- **Flexible configuration facilities**
 - provided locally via local keys combined with LCD indicator or via hand held terminal or PC configuration platform
- **Multiple protocol availability**
 - provides integration with HART®, PROFIBUS PA and FOUNDATION Fieldbus platforms offering interchangeability and transmitter upgrade capabilities
- **Full compliance with PED Category III**



**ABB 2600T Series
Engineered solutions
for all applications**

Functional Specifications

Range and span limits

Sensor Code	Upper Range Limit (URL)	Lower Range Limit (LRL)	Minimum span
C	6kPa 60mbar 24inH ₂ O	-6kPa -60mbar -24inH ₂ O	0.2kPa 2mbar 0.8inH ₂ O
F	40kPa 400mbar 160inH ₂ O	-40kPa -400mbar -160inH ₂ O	0.4kPa 4mbar 1.6inH ₂ O
L	250kPa 2500mbar 1000inH ₂ O	-250kPa -2500mbar -1000inH ₂ O	2.5kPa 25mbar 10inH ₂ O
N	2000kPa 20bar 290psi	-2000kPa -20bar -290psi	20kPa 0.2bar 2.9psi

Span limits

Maximum span = URL
(can be further adjusted up to \pm URL (TD = 0.5) for differential models, within the range limits)

IT IS RECOMMENDED TO SELECT THE TRANSMITTER SENSOR CODE PROVIDING THE TURNDOWN VALUE AS LOWEST AS POSSIBLE TO OPTIMIZE PERFORMANCE CHARACTERISTICS.

Zero suppression and elevation

Zero and span can be adjusted to any value within the range limits detailed in the table as long as:

- calibrated span \geq minimum span

Damping

Selectable time constant : 0, 0.25, 0.5, 1, 2, 4, 8 or 16s.
This is in addition to sensor response time

Turn on time

Operation within specification in less than 1s with minimum damping.

Insulation resistance

> 100M Ω at 1000VDC (terminals to earth)

Operative limits

Temperature limits °C (°F) :

Ambient (is the operating temperature)

Silicone oil filling: -40°C and $+85^{\circ}\text{C}$ (-40°F and $+185^{\circ}\text{F}$)

Inert filling: -20°C and $+85^{\circ}\text{C}$ (-4°F and $+185^{\circ}\text{F}$)

Lower ambient limit for LCD indicators: -20°C (-4°F)

Upper ambient limit for CoMeter and ProMeter : $+70^{\circ}\text{C}$ ($+158^{\circ}\text{F}$)

Note : For Hazardous Atmosphere applications see the temperature range specified on the certificate/approval relevant to the aimed type of protection

Process

Lower limit

- Refer to lower ambient limits; -20°C (-4°F) for Viton gasket

Upper limit

- Silicone oil: 121°C (250°F)
for working pressure above 10kPa abs, 100mbar abs, 1.45psia(1)

- Inert fluid: 121°C (250°F) (2)
for working pressure above atmospheric pressure

- (1) 85°C (185°F) for application below 10kPa abs, 100mbar abs, 1.45psia down to 3.5 kPa abs, 35mbar abs, 0.5psia
- (2) 85°C (185°F) for application below atmospheric pressure down to 40kPa abs, 400mbar abs, 5.8psia

Storage

Lower limit: -50°C (-58°F); -40°C (-40°F) for LCD indicators

Upper limit: $+85^{\circ}\text{C}$ ($+185^{\circ}\text{F}$)

Pressure limits

Overpressure limits (without damage to the transmitter)

Lower limit

- 0.5kPa abs, 5mbar abs, 0.07psia for silicone oil
- 40kPa abs, 400mbar abs, 5.8psia for inert fluid

Upper limit

- 41MPa, 410bar, 5945psi

Static pressure

Transmitters for high static differential pressure model 264BS operates within specifications between the limits of:

Lower limit

- 0.5kPa abs, 5mbar abs, 0.07psia for silicone oil
- 40kPa abs, 400mbar abs, 5.8psia for inert fluid

Upper limit

- 41MPa, 410bar, 5945psi

Proof pressure

The transmitter can be exposed without leaking to line pressure of up to 1.5 times the nominal pressure simultaneously on both sides.

Environmental limits

Electromagnetic compatibility (EMC)

Comply with EN 61000–6–3 for emission and EN 61000–6–2 for immunity requirements and test;

Radiated electromagnetic immunity level: 30V/m
(according to IEC 1000–4–3, EN61000–4–3)

Conducted electromagnetic immunity level : 30V
(according to IEC 1000–4–6, EN 61000–4–6)

Surge immunity level (with surge protector): 4kV
(according to IEC 1000–4–5 EN 61000–4–5)

Fast transient (Burst) immunity level: 4kV
(according to IEC 1000–4–4 EN 61000–4–4)

Pressure equipment directive (PED)

Comply with 97/23/EEC Category III Module H.

Humidity

Relative humidity: up to 100% annual average

Condensing, icing: admissible

Vibration resistance

Accelerations up to 2g at frequency up to 1000Hz
(according to IEC 60068–2–26)

Shock resistance

Acceleration: 50g

Duration: 11ms

(according to IEC 60068–2–27)

Wet and dust-laden atmospheres

The transmitter is dust and sand tight and protected against immersion effects as defined by EN 60529 (1989) to IP 67 (IP 68 on request) or by NEMA to 4X or by JIS to C0920.

Hazardous atmospheres

With or without output meter/integral display

– INTRINSIC SAFETY/EUROPE:

ATEX/ZELM approval

EC-Type Examination Certificate no. ZELM 02 ATEX 0081 (HART)

II 1 GD T50°C, EEx ia IIC T6 (–40°C ≤ Ta ≤ +40°C)

T95°C, EEx ia IIC T4 (–40°C ≤ Ta ≤ +85°C)

(FOUNDATION Fieldbus/PROFIBUS PA–FISCO): pending

– TYPE "N"/EUROPE:

ATEX/ZELM type examination :

Design compliance by certificate no. ZELM 02 ATEX 3088 (HART)

II 3 GD T50°C, EEx nL IIC T6 (–40°C ≤ Ta ≤ +40°C)

T95°C, EEx nL IIC T4 (–40°C ≤ Ta ≤ +85°C)

(FOUNDATION Fieldbus/PROFIBUS PA): pending

– FLAMEPROOF/EUROPE:

ATEX/CESI approval

EC-Type Examination Certificate no. CESI 02 ATEX 027

II 1/2 GD T85°C, EEx d IIC T6 (–40°C ≤ Ta ≤ +75°C)

– CANADIAN STANDARDS ASSOCIATION

and FACTORY MUTUAL: pending

– Explosionproof: Class I, Div. 1, Groups A, B, C, D

– Dust ignitionproof : Class II, Div. 1, Groups E, F, G

– Suitable for : Class II, Div. 2, Groups F, G; Class III, Div. 1, 2

– Nonincendive: Class I, Div. 2, Groups A, B, C, D

– Intrinsically safe: Class I, II, III, Div. 1, Groups A, B, C, D, E, F, G

AEx ia IIC T6/T4, Zone 0 (FM)

– STANDARDS AUSTRALIA (SAA): pending

TS/WCA Approval

Ex d IIC T5 (Tamb +85°C)/T6 (Tamb +70°C) Class 1 Zone 1;

Ex ia IIC T4 (Tamb +85°C) /T5 (Tamb +55°C) T6 Class 1 Zone 0

Electrical Characteristics and Options

HART digital communication and 4 to 20mA output

Power Supply

The transmitter operates from 10.5 to 42VDC with no load and is protected against reverse polarity connection (additional load allows operations over 42VDC).

For EEx ia and other intrinsically safe approval power supply must not exceed 30VDC.

Ripple

20mV max on a 250Ω load as per HART specifications

MINIMUM OPERATING VOLTAGES

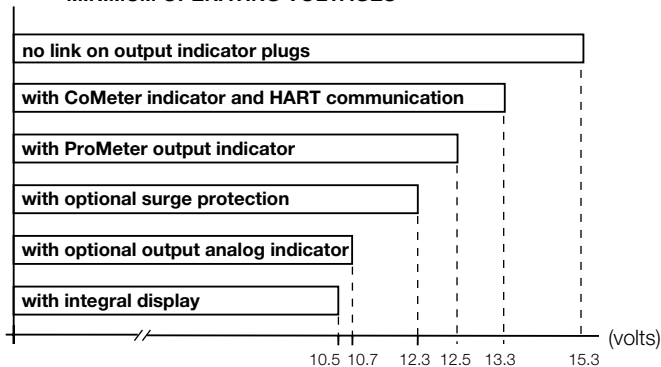

Load limitations

4 to 20mA and HART total loop resistance :

$$R(k\Omega) = \frac{\text{Supply voltage} - \text{min. operating voltage (VDC)}}{22.5}$$

A minimum of 250Ω is required for HART communication.

Optional indicators

Output meter

CoMeter and Prometer :

5-digit (± 99999 counts) programmable with 7.6mm. high (3in), 7-segment numeric characters plus sign and digital point for digital indication of output value in percentage, current or engineer unit;

10-segment bargraph display (10% per segment) for analog indication of output in percentage;

7-digit LCD with 6mm. high (2.3in), 14-segment alphanumeric characters, for engineer units and configuration display

Analog : 36mm (1.4in) scale on 90°.

Integral display

LCD, 15 lines x 56 column dot matrix providing 2 lines indication as

– top: 5-digit (numeric) plus sign or 7-digit alphanumeric

– bottom: 7-digit alphanumeric

and additional 50-segment bargraph for indication of analog output in percentage.

User-definable matrix display mode with HART communication:

– process variable in pressure unit or

– output signal as percentage, current or engineering units

Display also indicates in/out transfer function, static pressure, sensor temperature and diagnostic messages and provides configuration facilities.

Optional surge protection

Up to 4kV

– voltage 1.2μs rise time / 50μs delay time to half value

– current 8μs rise time / 20μs delay time to half value

Output signal

Two-wire 4 to 20mA, user-selectable for linear or square root output, power of $3/2$ or $5/2$, 5th order or two 2nd order switching point selectable programmable polynomial output.

HART® communication provides digital process variable (% , mA or engineering units) superimposed on 4 to 20mA signal, with protocol based on Bell 202 FSK standard.

Output current limits (to NAMUR standard)

Overload condition

- Lower limit: 3.8mA

- Upper limit: 20.5mA

Transmitter failure mode (to NAMUR standard)

The output signal can be user-selected to a value of 3.7 or 22mA on gross transmitter failure condition, detected by self-diagnostics.

In case of CPU failure the output is driven <3.7mA or >22mA.

PROFIBUS PA output

Device type

Pressure transmitter compliant to Profiles 3.0 Class A & B; ident. number 052B HEX.

Power supply

The transmitter operates from 10.5 to 32VDC, polarity independent.

For EEx ia approval power supply must not exceed 17.5VDC. Intrinsic safety installation according to FISCO model.

Current consumption

operating (quiescent): 10.5mA

fault current limiting: 20mA max.

Output signal

Physical layer in compliance to IEC 1158-2/EN 61158-2 with transmission to Manchester II modulation, at 31.25kbit/sec.

Output interface

PROFIBUS PA communication according to Profibus DP50170 Part 2/ DIN 19245 part 1-3.

Output update time

25ms

Function blocks

2 analog input, 1 transducer, 1 physical

Integral display

LCD, 15 lines x 56 column dot matrix providing 2 lines indication as

– top: 5-digit (numeric) plus sign or 7-digit alphanumeric

– bottom: 7-digit alphanumeric

and additional 50-segment bargraph for indication of output in percentage of the analog input function block assigned to the primary variable.

User-definable matrix display mode:

– process variable in pressure units or

– primary variable in engineering units (output of transducer block) or

– output as percentage or engineering units of analog input function blocks

Display also indicates diagnostic messages and provides configuration facilities.

Secondary variable, static pressure and sensor temperature can be read.

Transmitter failure mode

On gross transmitter failure condition, detected by self-diagnostics, the output signal can be driven to defined conditions, selectable by the user as safe, last valid or calculated value. If electronic failure or short circuit occur the transmitter consumption is electronically limited at a defined value (20mA approx), for safety of the network.

FOUNDATION Fieldbus output

Device type

LINK MASTER DEVICE

Link Active Scheduler (LAS) capability implemented.

Power supply

The transmitter operates from 9 to 32VDC, polarity independent.

For EEx ia approval power supply must not exceed 24VDC (entity certification) or 17.5VDC (FISCO certification), according to FF-816.

Current consumption

operating (quiescent): 10.5mA

fault current limiting: 20mA max.

Output signal

Physical layer in compliance to IEC 1158-2/EN 61158-2 with transmission to Manchester II modulation, at 31.25kbit/sec.

Function blocks/execution period

2 standard Analog Input blocks/25ms max (each)

1 standard PID block/70ms max.

Additional blocks

1 standard Resource block,

1 custom Pressure with calibration transducer block.

Number of link objects

25

Number of VCRs

24

Output interface

FOUNDATION fieldbus digital communication protocol to standard H1, compliant to specification V. 1.5; FF registration in progress.

Integral display

LCD, 15 lines x 56 column dot matrix providing 2 lines indication as

– top: 5-digit (numeric) plus sign or 7-digit alphanumeric

– bottom: 7-digit alphanumeric

and additional 50-segment bargraph for indication of output in percentage of the analog input function block assigned to the primary variable.

User-definable matrix display mode:

– process variable in pressure units or

– primary variable in engineering units (output of transducer block) or

– output as percentage or engineering units of analog input function blocks

Display also indicates diagnostic messages and provides configuration facilities.

Secondary variable, static pressure and sensor temperature can be read.

Transmitter failure mode

The output signal is "frozen" to the last valid value on gross transmitter failure condition, detected by self-diagnostics which also indicate a BAD conditions. If electronic failure or short circuit occur the transmitter consumption is electronically limited at a defined value (20mA approx), for safety of the network.

Performance specifications

Stated at reference condition to IEC 60770 ambient temperature of 20°C (68°F), relative humidity of 65%, atmospheric pressure of 1013hPa (1013mbar), mounting position with vertical diaphragm and zero based range for transmitter with isolating diaphragms in AISI 316 L ss or Hastelloy and silicone oil fill and HART digital trim values equal to 4–20mA span end points, in linear mode.

Unless otherwise specified, errors are quoted as % of span.

Some performance data are affected by the actual turndown (TD) as ratio between Upper Range Limit (URL) and calibrated span.

IT IS RECOMMENDED TO SELECT THE TRANSMITTER SENSOR CODE PROVIDING THE TURNDOWN VALUE AS LOWEST AS POSSIBLE TO OPTIMIZE PERFORMANCE CHARACTERISTICS.

Dynamic performance (according to IEC 61298–1 definition)

Standard configuration with turndown up to 30:1 and linear output characteristic.

Dead time: 40ms

Time constant (63.2% of total step change):

– sensors F, L, N: 150ms

– sensor C: 400ms

Response time (total) = dead time + time constant

Accuracy rating

% of calibrated span, including combined effects of terminal based linearity, hysteresis and repeatability.

For fieldbus versions SPAN refer to analog input function block outscale range

– ±0.075% for TD from 1:1 to 15:1

– $\pm 0.005\% \times \frac{\text{URL}}{\text{Span}}$ for TD from 15:1 to 60:1
(30:1 for sensor code C)

Operating influences

Ambient temperature

per 20K (36°F) change between the limits of –20°C to +65°C (–4 to +150°F) :

Model	Sensor Code	for TD up to	
264BS	F, L, N	15:1	± (0.04% URL + 0.065% span)
	C	10:1	± (0.06% URL + 0.10% span)

Optional CoMeter and ProMeter ambient temperature

Total reading error per 20K (36°F) change between the ambient limits of –20 and +70°C (–4 and +158°F) :

±0.15% of max span (16mA).

Static pressure (zero errors can be calibrated out at line pressure)

per 10MPa, 100bar or 1450psi

Model 264BS

– zero error: ±0.15% of URL

– span error: ±0.15% of reading

Supply voltage

Within voltage/load specified limits the total effect is less than 0.005% of URL per volt.

Load

Within load/voltage specified limits the total effect is negligible.

Radio frequency interference

Total effect : less than 0.10% of span from 20 to 1000MHz and for field strengths up to 30V/m when tested with shielded conduit and grounding, with or without meter.

Common mode interference

No effect from 100Vrms @ 50Hz, or 50VDC

Mounting position

Rotations in plane of diaphragm have negligible effect. A tilt from vertical causes a zero shifts of $\sin \alpha \times 0.35\text{kPa}$ (3.5mbar, 1.4inH₂O) of URL which can be corrected with the zero adjustment. No span effect.

Stability

±0.10% of URL over a thirty-six-month period

Vibration effect

±0.10% of URL (according to IEC 61298–3)

Physical Specification

(Refer to ordering information sheets for variant availability related to specific model or versions code)

Materials

Process isolating diaphragms (*)

AISI 316 L ss; Hastelloy C276™; Monel 400™; Tantalum;

Process flanges, adapters, plugs and drain/vent valves (*)

AISI 316 L ss; Hastelloy C276™; Monel 400™.

Sensor fill fluid

Silicone oil; inert fill (carbon fluoride)

Mounting bracket (**)

Zinc plated carbon steel with chrome passivation;

AISI 316 L ss.

Gaskets (*)

Viton™; Perbunan (NBR), EPDM.

Sensor housing

AISI 316 L ss.

Bolts and nuts

AISI 316 ss bolts and nuts Class A4–50 per UNI 7323 (ISO 3506), in compliance with NACE MR0175 Class II.

Electronic housing and covers

Barrel version

– Copper-free content aluminium alloy with baked epoxy finish;

– Low-copper content aluminium alloy with baked epoxy finish;

– AISI 316 L ss.

DIN version

– Low-copper content aluminium alloy with baked epoxy finish.

Covers O-ring

Buna N.

Local zero and span adjustments:

Glass filled polycarbonate plastic (removable).

Tagging

AISI 316ss data plate attached to the electronics housing.

Calibration

Standard: at maximum span, zero based range, ambient temperature and pressure;

Optional: at specified range and ambient conditions.

Optional extras

Mounting brackets

For vertical and horizontal 60mm. (2in) pipes or wall mounting.

Output indicator

plug-in rotatable type, LCD or analog.

Supplemental customer tag

AISI 316 ss tag screwed/fastened to the transmitter for customer's tag data up to a maximum of 20 characters and spaces on one line for tag number and tag name, and up to a maximum of 3 spaced strings of 10 characters each for calibration details (lower and upper values plus unit). Special typing evaluated on request for charges.

Surge protection (only as external unit for PROFIBUS PA and FF)

Hydrogen or special service preparation

Test Certificates (test, design, calibration, material traceability)

Tag and manual language

Communication connectors

Process connections

on flanges : 1/4in NPT on process axis

on adapters : 1/2in NPT on process axis

centre distance: 54mm (2.13in) on flange;

51,54 or 57mm (2.01, 2.13 or 2.24in) as per adapters fittings.

fixing threads: 7/16in–20 UNF at 41.3mm centre distance

Electrical connections

Two 1/2 NPT or M20x1.5 or PG 13.5 or 1/2 GK threaded conduit entries, direct on housing.

Special communication connector (on request)

– HART : straight or angle Harting HAN connector and one plug.

– FOUNDATION Fieldbus, PROFIBUS PA: M12x1 or 7/8.

Terminal block

HART version: three terminals for signal/external meter wiring up to 2.5mm² (14AWG) and three connection points for test and communication purposes.

Fieldbus versions: two terminals for signal wiring (bus connection) up to 2.5mm² (14AWG)

Grounding

Internal and external 6mm² (10AWG) ground termination points are provided.

Mounting position

Transmitter can be mounted in any position.

Electronics housing may be rotated to any position. A positive stop prevents over travel.

Mass (without options)

3.5kg approx (8lb); add 1.5kg (3.4lb) for AISI housing.

Add 650g (1.5lb) for packing.

Packing

Carton 26 x 26 x 18cm approx (10 x 10 x 7in).

Configuration

Transmitter with HART communication and 4 to 20 mA

Standard configuration

Transmitters are factory calibrated to customer's specified range. Calibrated range and tag number are stamped on the tag plate. If a calibration range and tag data are not specified, the transmitter will be supplied with the plate left blank and configured as follows:

Engineering Unit	Specify from table
4 mA	Zero
20 mA	Upper Range Limit (URL)
Output	Linear
Damping	1 sec.
Transmitter failure mode	Upscale
Software tag characters	Blank
Optional LCD output indicator	0 to 100.0% linear

Any or all the above configurable parameters, including Lower range-value and Upper range-value which must be the same unit of measure, can be easily changed using the HART hand-held communicator. The transmitter database is customized with specified flange type and material, O-ring and drain/vent materials and meter code option.

Custom configuration (option)

The following data may be specified in addition to the standard configuration parameters:

Descriptor	16 alphanumeric characters
Message	32 alphanumeric characters
Date	Day, month, year

Transmitter with PROFIBUS PA communication

Transmitters are factory calibrated to customer's specified range. Calibrated range and tag number are stamped on the tag plate. If a calibration range and tag data are not specified, the transmitter will be supplied with the plate left blank and configured as follows:

Measure Profile	Pressure
Engineering Unit	kPa
Output scale 0%	Lower Range Limit (LRL)
Output scale 100%	Upper Range Limit (URL)
Output	Linear
Hi-Hi Limit	Upper Range Limit (URL)
Hi Limit	Upper Range Limit (URL)
Low Limit	Lower Range Limit (LRL)
Low-Low Limit	Lower Range Limit (LRL)
Limits hysteresis	0.5% of output scale
PV filter	0 sec.
Address (settable by local key)	126
Tag	32 alphanumeric characters

Any or all the above configurable parameters, including Lower range-value and Upper range-value which must be the same unit of measure, can be easily changed by a PC running the configuration software Smart Vision with DTM for 2600T.

The transmitter database is customized with specified flange type and material, O-ring and drain/vent materials and meter code option.

Custom configuration (option)

The following data may be specified in addition to the standard configuration parameters:

Descriptor	32 alphanumeric characters
Message	32 alphanumeric characters
Date	Day, month, year

Transmitter with FOUNDATION Fieldbus communication

Transmitters are factory calibrated to customer's specified range. Calibrated range and tag number are stamped on the tag plate. If a calibration range and tag data are not specified, the transmitter will be supplied with the plate left blank and the analog input function block FB1 is configured as follows:

Measure Profile	Pressure
Engineering Unit	kPa
Output scale 0%	Lower Range Limit (LRL)
Output scale 100%	Upper Range Limit (URL)
Output	Linear
Hi-Hi Limit	Upper Range Limit (URL)
Hi Limit :	Upper Range Limit (URL)
Low Limit	Lower Range Limit (LRL)
Low-Low Limit	Lower Range Limit (LRL)
Limits hysteresis	0.5% of output scale
PV filter time	0 sec.
Tag	32 alphanumeric characters

The analog input function block FB2 is configured for the sensor temperature measured in °C. Any or all the above configurable parameters, including the range values, can be changed using any host compliant to FOUNDATION fieldbus. The transmitter database is customized with specified flange type and material, O-ring and drain/vent materials and meter code option.

For any protocol available engineering units of pressure measure are :

Pa, kPa, MPa
 inH₂O@4°C, mmH₂O@4°C, psi
 inH₂O@20°C, ftH₂O@20°C, mmH₂O@20°C
 inHg, mmHg, Torr
 g/cm², kg/cm², atm
 mbar, bar

™ Hastelloy is a Cabot Corporation trademark

™ Monel is an International Nickel Co. trademark

™ Galden is a Montefluos trademark

™ Viton is a Dupont de Nemour trademark

(*) Wetted parts of the transmitter.

(**) U-bolt material: AISI 400 ss; screws material: high-strength alloy steel or AISI 316 ss.

MOUNTING DIMENSIONS (not for construction unless certified) - dimensions in mm (in)

Transmitter with barrel aluminium housing on bracket for vertical or horizontal 60mm (2in) pipe mounting

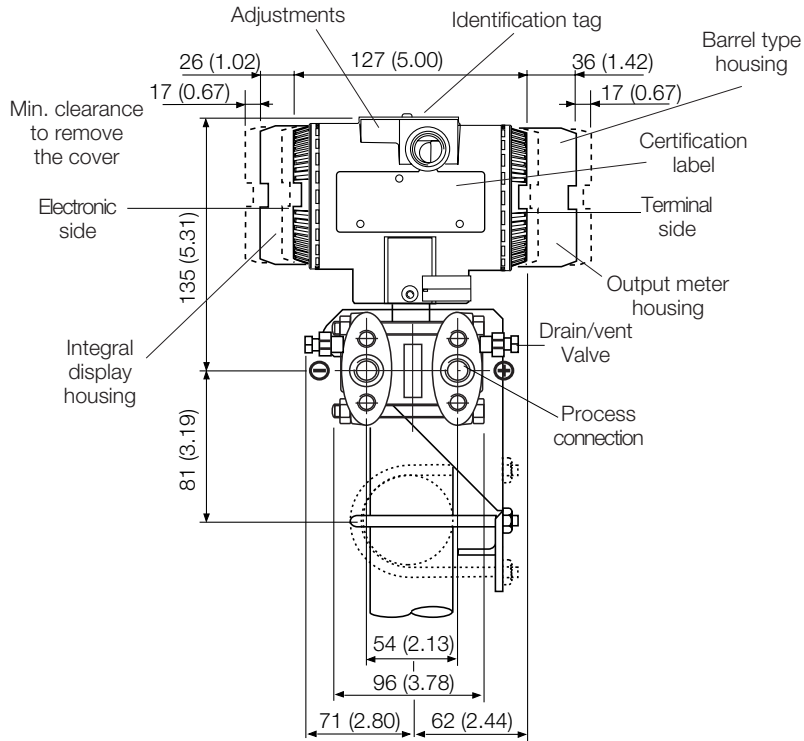

(*) 51 (2.01), 54 (2.13) or 57 (2.24) mm (in) according to 1/2in 14 NPT adapters fitting 54 (2.13) mm (in) on 1/4in 18 NPT process flange 54 (2.13) mm (in) with low pressure side flange without process connection and drain/vent valve

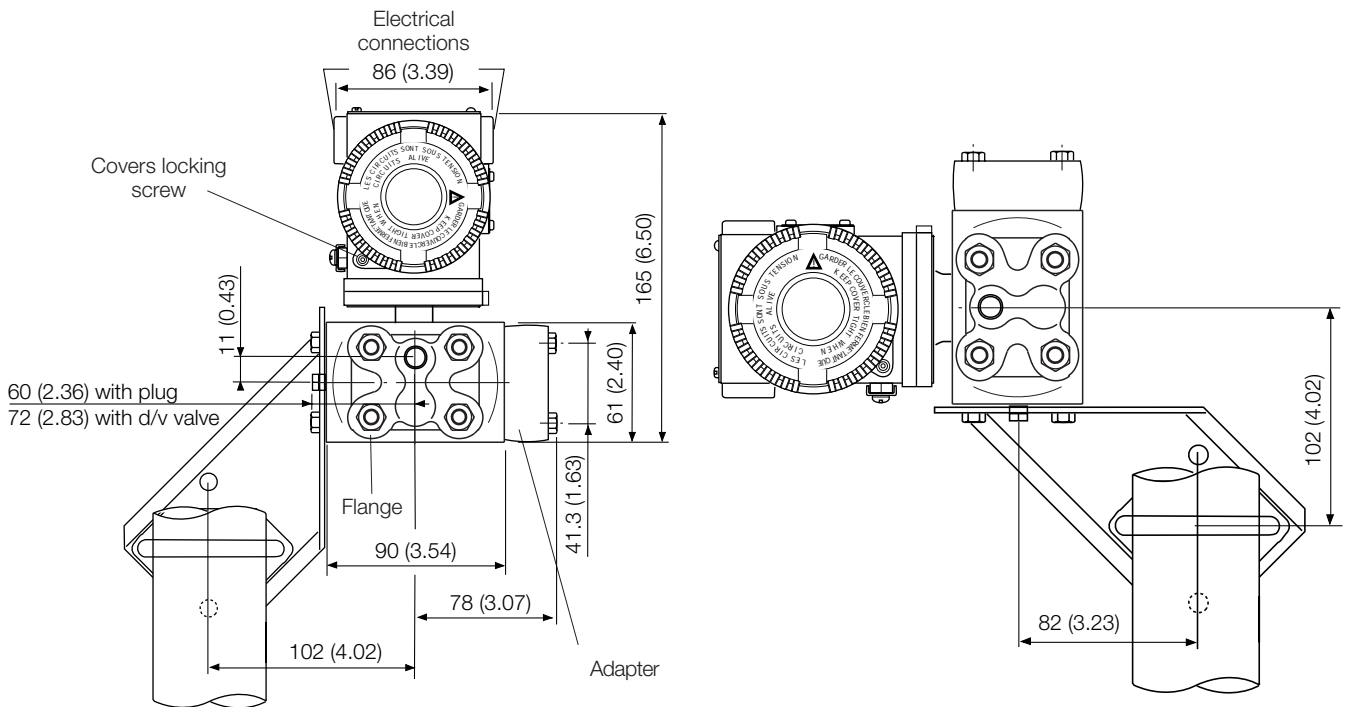

NOTE : Process connection, gasket groove and gaskets are in accordance with DIN 19213. Bolting threads for fixing adapter or other devices (i.e. manifold etc.) on process flange is 7/16in-20 UNF.

Transmitter on bracket for vertical or horizontal 60 mm (2in) pipe mounting (DIN housing)

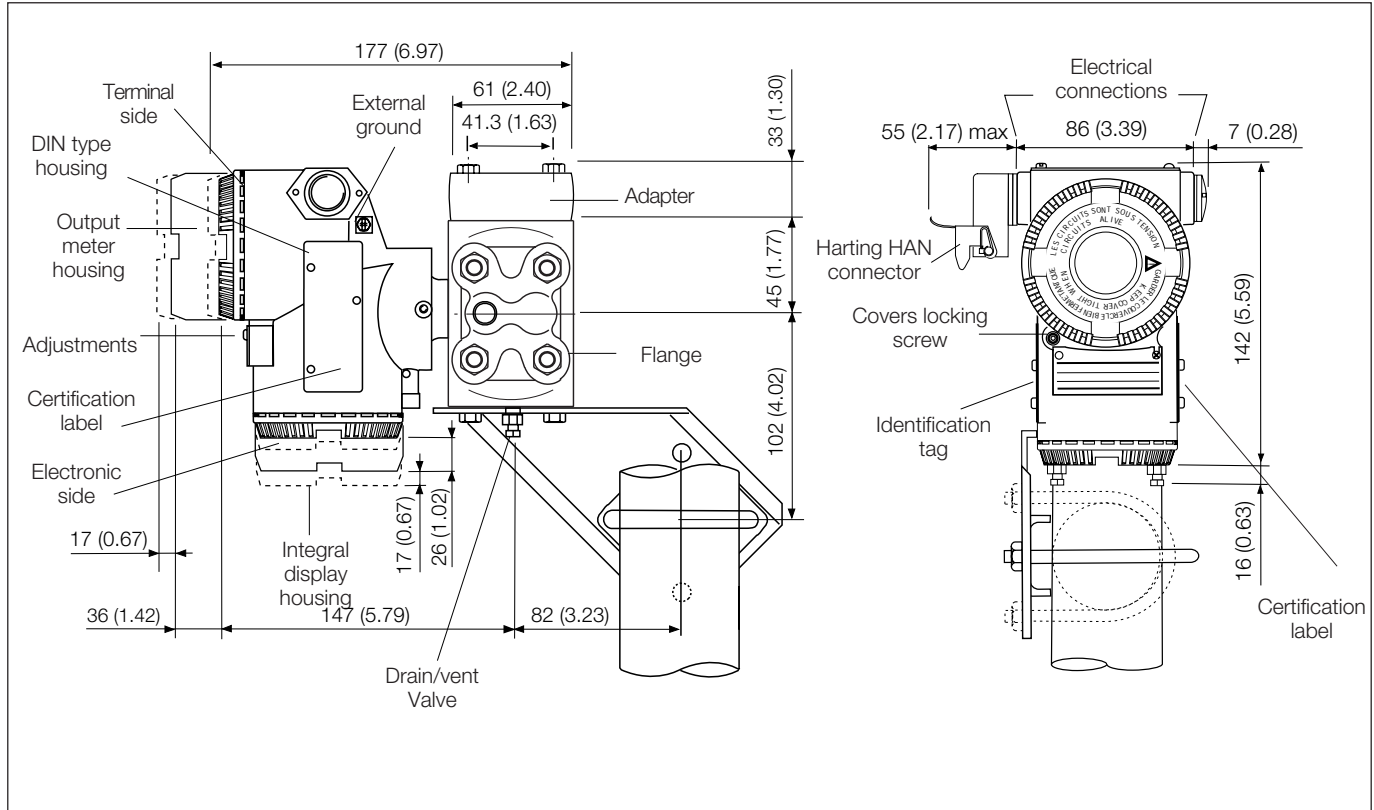

Transmitter with barrel AISI ss housing on bracket (flat type for box) for vertical or horizontal 60mm (2in) pipe mounting

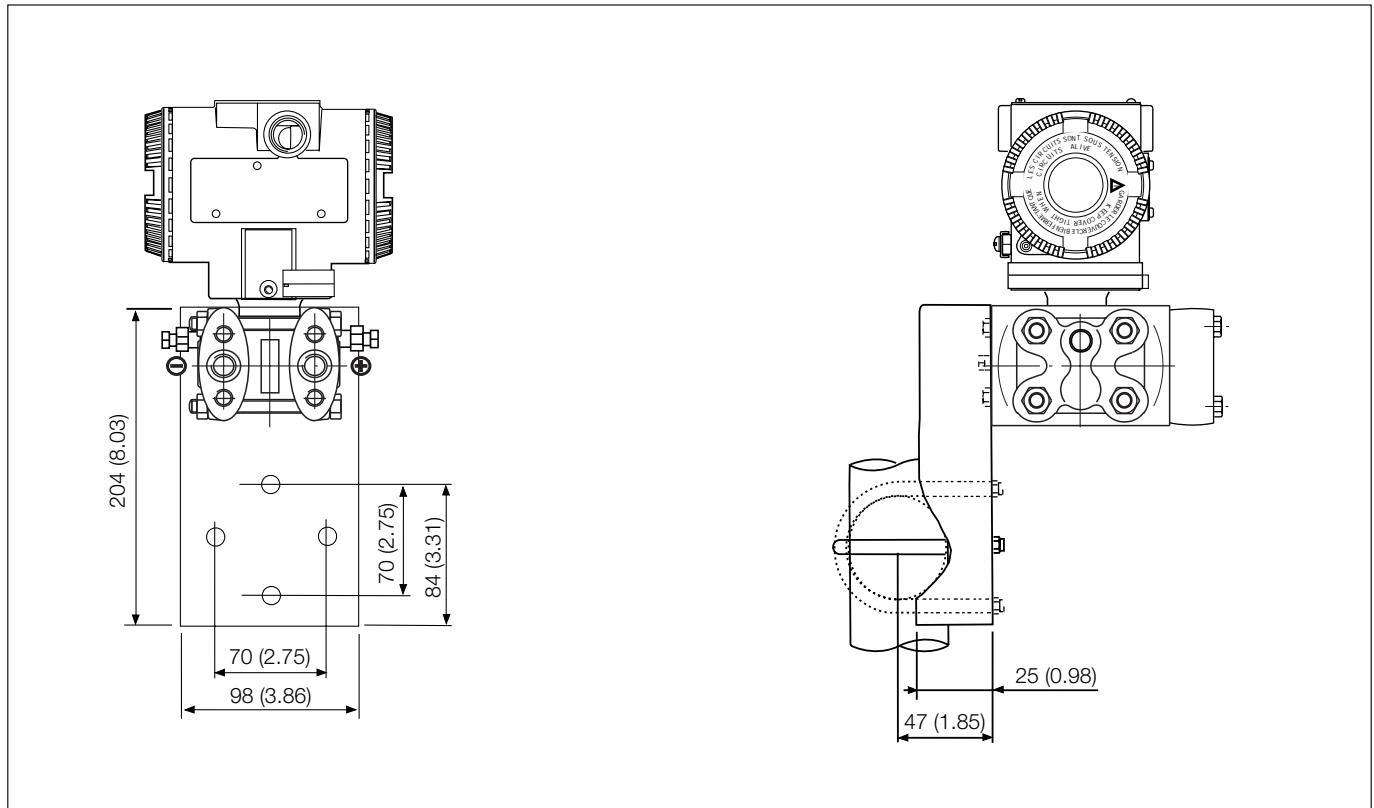

Electrical connections

HART Version

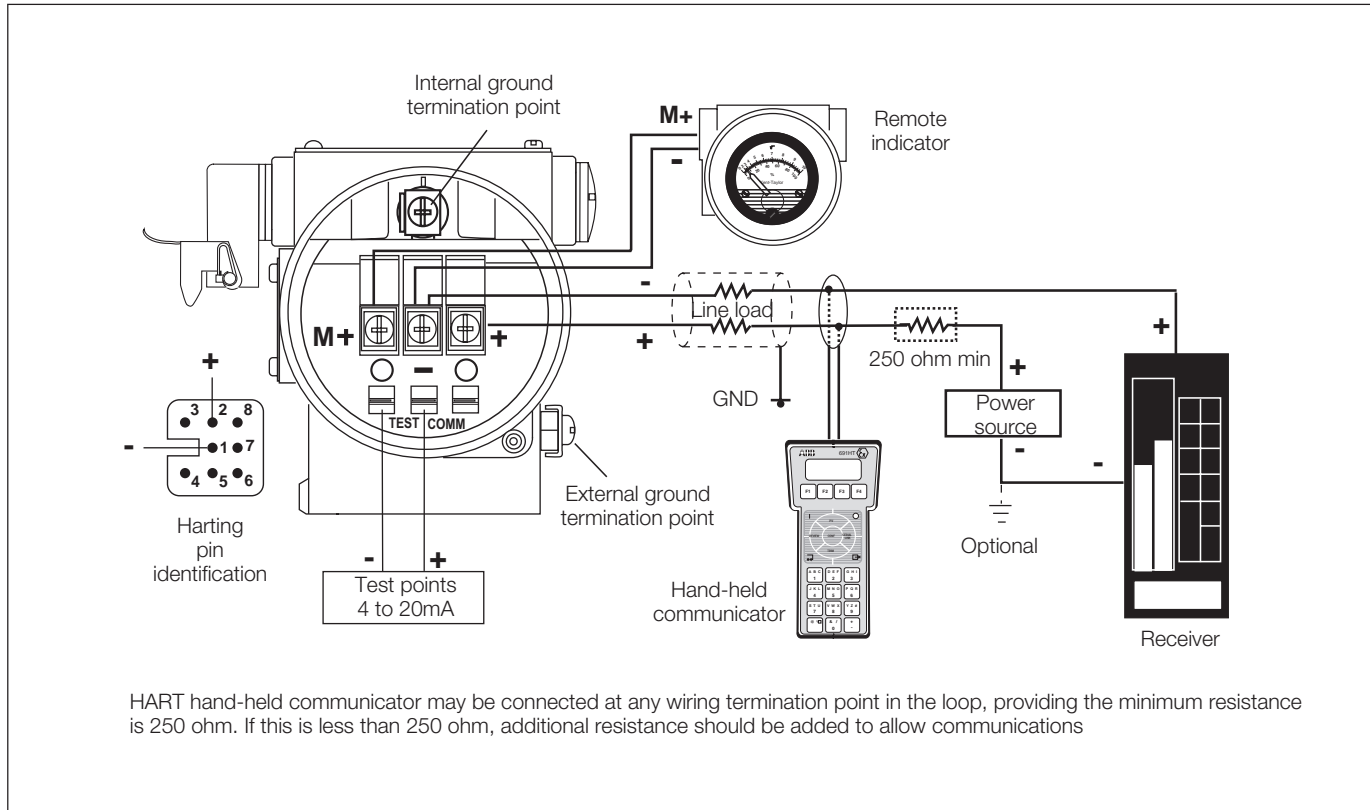

FIELDBUS Versions

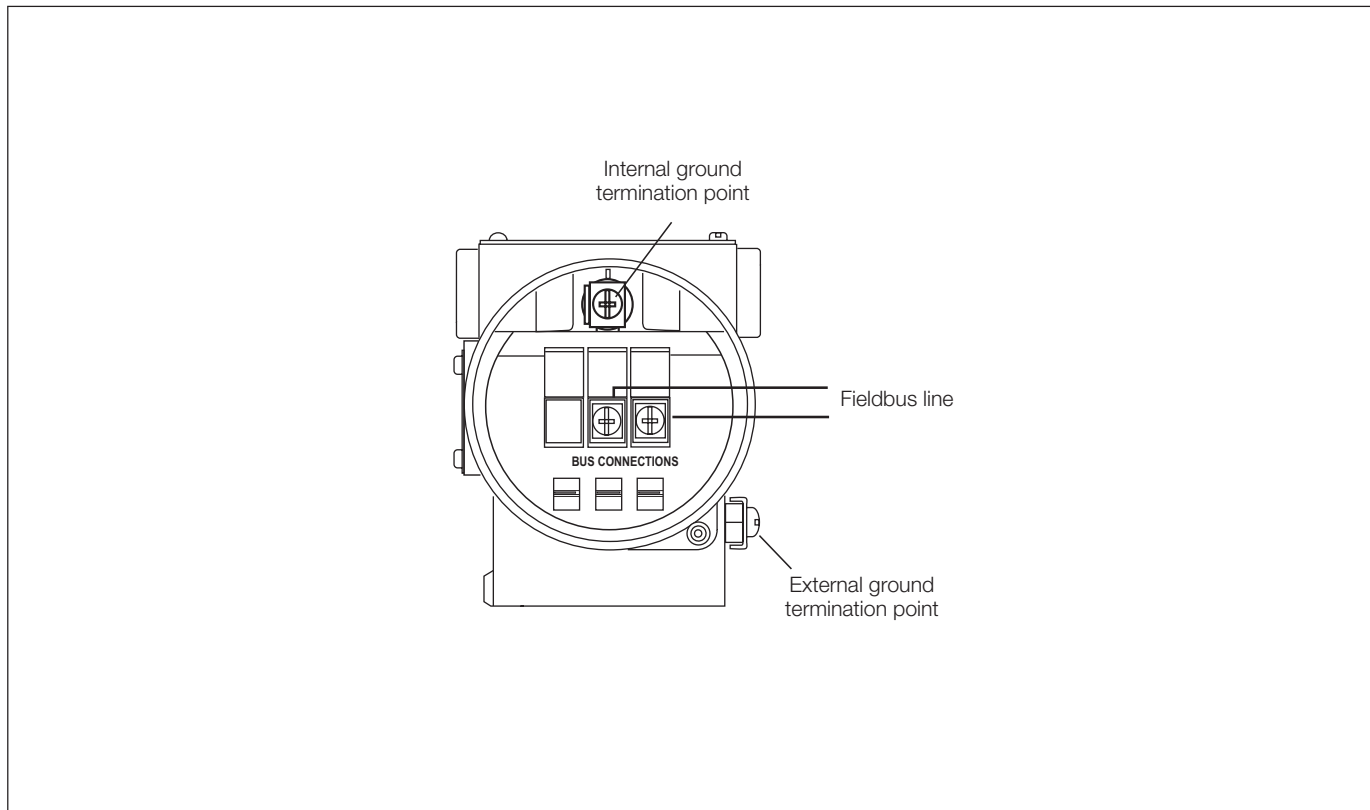

BASIC ORDERING INFORMATION model 264BS Differential Pressure Transmitter (High static)

Select one character or set of characters from each category and specify complete catalog number.
Refer to additional ordering information code and specify one or more codes for each transmitter if additional options are required.

BASE MODEL – 1 st to 5 th characters			2	6	4	B	S	X	X	X	X	X	X
Differential Pressure Transmitter (High static) – BASE ACCURACY 0.075%													
SENSOR - Span limits – 6th character													
0.2 and 6kPa	2 and 60mbar	0.8 and 24inH ₂ O						C					
0.4 and 40kPa	4 and 400mbar	1.6 and 160inH ₂ O						F					
2.5 and 250kPa	25 and 2500mbar	10 and 1000inH ₂ O						L					
20 and 2000kPa	0.2 and 20bar	2.9 and 290psi						N					
Diaphragm material / Fill fluid (wetted parts) – 7th character													
AISI 316 L ss		Silicone oil						NACE	S				
Hastelloy C276™		Silicone oil						NACE	K				
Monel 400™		Silicone oil						NACE	M				
AISI 316 L ss		Inert fluid						NACE	A				
Hastelloy C276™		Inert fluid						NACE	F				
Tantalum		Inert fluid						NACE	D				
Process flanges/adapters material and connection (wetted parts) – 8th character													
AISI 316 L ss (Horizontal connection)		1/2in NPT-f direct (7/16in UNF U.S. drilling)						NACE		A			
AISI 316 L ss (Horizontal connection)		1/2in NPT-f through adapter (7/16in UNF U.S. drilling)						NACE		B			
Hastelloy C276™ (Horizontal connection)		1/2in NPT-f direct (7/16in UNF U.S. drilling)						NACE		D			
Hastelloy C276™ (Horizontal connection)		1/2in NPT-f through adapter (7/16in UNF U.S. drilling)						NACE		E			
Monel 400™ (Horizontal connection)		1/2in NPT-f direct (7/16in UNF U.S. drilling)						NACE		G			
Monel 400™ (Horizontal connection)		1/2in NPT-f through adapter (7/16in UNF U.S. drilling)						NACE		H			
Bolts/Gasket (wetted parts) – 9th character													
AISI 316 ss (NACE)		Viton™						NACE			3		
AISI 316 ss (NACE)		EPDM						NACE			5		
AISI 316 ss (NACE)		Perbunan						NACE			6		
Housing material and electrical connection – 10th character													
Aluminium alloy (Barrel version)		1/2in NPT										A	
Aluminium alloy (Barrel version)		M20 x 1.5 (CM 20)										B	
Aluminium alloy (Barrel version)		Pg 13.5										D	
Aluminium alloy (Barrel version)		1/2in GK										C	
Aluminium alloy (Barrel version)		Harting HAN connector					(Note 1) (general purpose only)					E	
Aluminium alloy (Barrel version)		Fieldbus connector					(Note 1) (general purpose only)					G	
Aluminium alloy copper-free (Barrel version)		1/2in NPT										H	
Aluminium alloy copper-free (Barrel version)		M20 x 1.5 (CM 20)										L	
Aluminium alloy copper-free (Barrel version)		Pg 13.5										N	
Aluminium alloy copper-free (Barrel version)		1/2in GK										M	
Aluminium alloy copper-free (Barrel version)		Harting HAN connector					(Note 1) (general purpose only)					P	
Aluminium alloy copper-free (Barrel version)		Fieldbus connector					(Note 1) (general purpose only)					R	
AISI 316 L ss (Barrel version)		1/2in NPT										S	
AISI 316 L ss (Barrel version)		M20 x 1.5 (CM20)										T	
AISI 316 L ss (Barrel version)		Pg 13.5										V	
AISI 316 L ss (Barrel version)		1/2in GK										U	
AISI 316 L ss (Barrel version)		Fieldbus connector					(Note 1) (general purpose only)					Z	
Aluminium alloy (DIN version)		M20 x 1.5 (CM 20)					(general purpose only)					J	
Aluminium alloy (DIN version)		Pg 13.5					(general purpose only)					Y	
Aluminium alloy (DIN version)		Harting HAN connector					(Note 1) (general purpose only)					K	
Aluminium alloy (DIN version)		Fieldbus connector					(Note 1) (general purpose only)					W	
Output/Additional options – 11th character													
HART digital communication and 4 to 20mA		No additional options					(Notes 2, 3)						H
HART digital communication and 4 to 20mA		Options requested (to be ordered by "Additional ordering code")					(Note 2)						1
PROFIBUS PA		No additional options					(Notes 2, 3)						P
PROFIBUS PA		Options requested (to be ordered by "Additional ordering code")					(Note 3)						2
FOUNDATION Fieldbus		No additional options					(Notes 2, 3)						F
FOUNDATION Fieldbus		Options requested (to be ordered by "Additional ordering code")					(Note 3)						3

ADDITIONAL ORDERING INFORMATION for model 264BS

Add one or more 2-digit code(s) after the basic ordering information to select all required options

	XX	XX	XX	XX	XX	XX	XX	XX	XX	XX	XX	XX	XX	XX	XX
Drain/vent valve (material and position) (wetted parts)															
AISI 316 L ss on process axis (Note 4)	NACE	V1													
AISI 316 L ss on flange side top (Note 4)	NACE	V2													
AISI 316 L ss on flange side bottom (Note 4)	NACE	V3													
Hastelloy C276™ on process axis (Note 5)	NACE	V4													
Hastelloy C276™ on flange side top (Note 5)	NACE	V5													
Hastelloy C276™ on flange side bottom (Note 5)	NACE	V6													
Monel 400™ on process axis (Note 6)	NACE	V7													
Monel 400™ on flange side top (Note 6)	NACE	V8													
Monel 400™ on flange side bottom (Note 6)	NACE	V9													
Electrical certification															
ATEX Group II Category 1 GD – Intrinsic Safety EEx ia	E1														
ATEX Group II Category 1/2 GD – Flameproof EEx d	E2														
ATEX Group II Category 3 GD – Type of protection "N" EEx nL design compliance	E3														
Factory Mutual (FM) / Canadian Standard Association (CSA) (only 1/2in NPT, M20 and Pg 13.5 housing)	E4														
Intrinsic Safety–Flameproof to Standards Australia SAA Ex ia IIC T6/T5/T4 + Ex d II C T6/T5 (Note 7)	E5														
Factory Mutual (FM) approval (only with 1/2in NPT, M20 and Pg 13.5 electrical connection)	E6														
Output meter															
ProMeter, Standard calibration (Note 7)	D1														
ProMeter, Special calibration (Note 7)	D2														
Analog output indicator linear 0–100% scale (Note 7)	D3														
Analog output indicator square root 0–10 scale (Note 7)	D4														
Analog output indicator, special graduation (to be specified for linear scale) (Note 7)	D5														
Analog output indicator, special graduation (to be specified for square root scale) (Note 7)	D6														
Programmable signal meter and HART configurator (CoMeter) (Note 7)	D7														
Programmable signal meter and HART configurator (CoMeter – customer configuration) (Note 7)	D8														
Integral LCD															
Digital LCD integral display	L1														
Mounting bracket (shape and material)															
For pipe mounting (Not suitable for AISI housing) Carbon steel	B1														
For pipe mounting (Not suitable for AISI housing) AISI 316 L ss	B2														
For wall mounting (Not suitable for AISI housing) Carbon steel	B3														
For wall mounting (Not suitable for AISI housing) AISI 316 L ss	B4														
Flat type for box AISI 316 L ss	B5														
Surge															
Surge/Transient Protector (Note 7)	S1														
Operating manual															
German	M1														
Italian	M2														
Labels & tag language															
German	T1														
Italian	T2														
Additional tag plate															
Laser printing of tag on stainless steel plate	I2														
Configuration															
Standard – Pressure = inH ₂ O/psi at 20° C; Temperature = deg. F	N2														
Standard – Pressure = inH ₂ O/psi at 4° C; Temperature = deg. F	N3														
Standard – Pressure = inH ₂ O/psi at 20° C; Temperature = deg.C	N4														
Standard – Pressure = inH ₂ O/psi at 4° C; Temperature = deg. C	N5														
Custom	N6														
Preparation procedure															
Hydrogen service preparation	P2														
Special services preparation	P4														
Certificates															
Inspection certificate EN 10204–3.1.B of calibration	C1														
Certificate of compliance with the order EN 10204–2.1 of instrument design	C6														
Material traceability															
Certificate of compliance with the order EN 10204–2.1 of process wetted parts	H1														
Inspection certificate EN 10204–3.1.B of process wetted parts	H3														
Connector															
Fieldbus 7/8 (Notes 3, 8)	U1														
Fieldbus M12x1 (Notes 3, 8)	U2														
Harting HAN – straight entry (Notes 2, 8)	U3														
Harting HAN – angle entry (Notes 2, 8)	U4														

- Note 1: Select type in additional ordering code
- Note 2: Not available with Electronic Housing code Z, R, G and W
- Note 3: Not available with Electronic Housing code P, E and K
- Note 4: Not available with Process flanges/adapters code D,E,G,H
- Note 5: Not available with Process flanges/adapters code A, B, G, H
- Note 6: Not available with Process flanges/adapters code A, B, D, E
- Note 7: Not available with PROFIBUS PA and FF output code 2 or 3
- Note 8: Not available with Electronic housing code U, S, T, V, H, M, L, N, D, C, A, B, J, Y

™ Hastelloy is a Cabot Corporation trademark

™ Monel is an International Nickel Co. trademark

™ Viton is a Dupont de Nemour trademark

Standard delivery items (can be differently specified by additional ordering code)

- Adapters supplied loose
- Plug on axis (no drain/vent valves)
- General purpose (no electrical certification)
- No meter/display, no mounting bracket, no surge protection
- English manual and labels
- Configuration with kPa and deg. C units
- No test, inspection or material traceability certificates

THE SELECTION OF SUITABLE WETTED PARTS AND FILLING FLUID FOR COMPATIBILITY WITH THE PROCESS MEDIA IS A CUSTOMER'S RESPONSIBILITY, IF NOT OTHERWISE NOTIFIED BEFORE MANUFACTURING.

ABB has Sales & Customer Support expertise in over 100 countries worldwide

www.abb.com

The Company's policy is one of continuous product improvement and the right is reserved to modify the information contained herein without notice.

Printed in Italy (09.02)

© ABB 2002



ABB Ltd

Howard Road, St. Neots
Cambridgeshire, PE19 3EU
UK
Tel: +44(0)1480 475321
Fax: +44(0)1480 217948

ABB Inc.

125 E. County Line Road
Warminster, PA 18974
USA
Tel: +1 215 674 6000
Fax: +1 215 674 7183

ABB Instrumentation spa

Via Statale 113
22016 Lenno (CO)
Italy
Tel: +39 0344 58111
Fax: +39 0344 56278

ABB Automation Products GmbH

Schillerstrasse 72
D-32425 Minden
Germany
Tel: +49 (0) 571 830 1691
Fax: +49 (0) 571 830 1368