

Thermal Mass Flowmeter FMT700-P (Sensyflow P)

for air, test benches

- **Direct mass flow measurement of air**
 - no additional pressure and temperature compensation required
- **Wide measuring range of 1:40**
- **Highest accuracy over the entire range**
 - measured error < 1 % of measured value
 - factory-calibrated, with (optional) DKD calibration certificate
- **Amazingly quick response time <12 ms**
 - detection of rapid load changes on engine test benches
- **Low pressure loss**
- **No moving parts**
 - no wear, maintenance-free
- **Complete system with inlet/outlet runs, air filter and links**
 - User-friendly handling
 - immediately ready for use
 - DN 25...DN 200
- **Separate supply/evaluation unit with display, diagnostic functions and various signal outputs**
 - ASAM GDI interface optionally
- **Reference system for intake air measurement of the leading car manufacturers worldwide**
- **Used in quality assurance, test bench applications, research & development**



High-end reference system
Quick response time
User-friendly handling

Function and system design

FMT700-P (Sensyflow P) operates according to the principle of a hot-film anemometer. With this measuring method the gas mass flow rate can be determined directly, without the need for pressure and temperature compensation.

FMT700-P (Sensyflow P) comprises a transducer (measuring tube), a supply/evaluation unit, and a measuring section.

The transducer is designed as a measuring tube and accommodates the sensor unit and an electronic transmitter circuit. It is available in 6 nominal sizes ranging from DN 25 to DN 200 and is installed in the measuring section by using quick-clamping connectors.

The measuring section consists of inlet and outlet runs of the appropriate size and of an air filter or flow conditioner which can be connected – e.g. to an air duct – via the connection piece on the suction side.

The supply/evaluation unit is available as a 19" plug-in version or as a desktop unit. It provides the power supply for the transducer and converts its flow-dependent current signal into standard analog mass flow signals.

The supply/evaluation unit with 6-digit display is suitable for all measuring tubes and automatically identifies the appropriate nominal size. Further diagnostic functions allow simple and safe operation. The measuring rate is adjustable according to measuring velocity or signal damping requirements. In case of high measuring velocity requirements the measuring rate can be reduced to 1 ms.

Available as option:

- gas temperature measurement
- measuring value as standard volume flow
- serial interface
- ASAM GDI interface
- connection for 2. transducer

Measuring principle

FMT700-P (Sensyflow P) operates according to the principle of the hot-film anemometer. This method of measurement is based on the abstraction of heat from a heated body by an enveloping gas flow. The flow-dependent cooling impact is used as the measuring effect.

The gas stream flows past two temperature-sensitive resistors R_h and R_T which are part of an electrical bridge circuit. Due to the chosen resistance ratio $R_h \ll R_T$, R_h is heated by the current I_h , and R_T adopts the same temperature as the gas. The current I_h is preset by the electronic control circuit to produce a constant temperature difference between the heated resistor R_h and the temperature of the gas.

The electrical power generated with resistor R_h exactly compensates its loss of heat to the gas flow. As this loss of heat is dependent on the number of particles which collide with the surface of resistor R_h , I_h represents a measure of the mass flow rate.

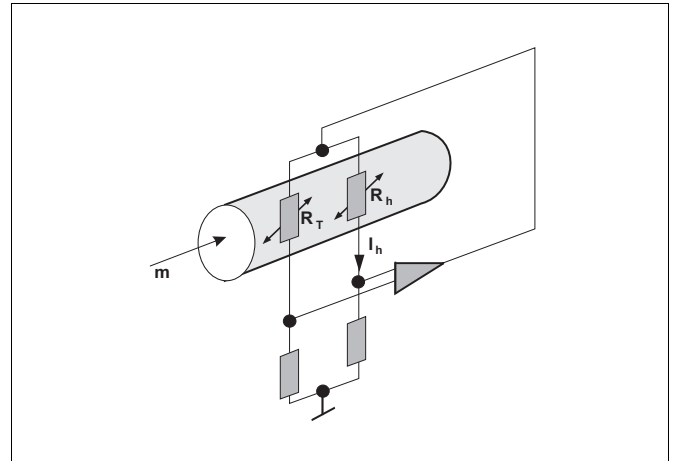

Typical applications

In a unique manner, FMT700-P (Sensyflow P) mass flow meters for air combine high accuracy, huge turn-down ratio and extremely fast response time. These features qualify them for the following application fields:

- Suction air measurements at combustion engines
- Test benches for turbo chargers
- Serial testing of flow dependent components like throttle valves, fans, air filters ...
- Quality assurance: reference unit for other flow meters
- Research & Development at universities and institutes

Ordering information

The measuring system consists of the following components:

1. Transducer/measuring tube
2. Supply/evaluation unit with measured value display unit
3. Measuring section with air filter or flow conditioner
4. Cables for connecting the transducer and the supply/evaluation unit

Technical data

Measuring principle

Thermal: hot-film anemometer

Input

Measured medium

Flow rate of air

Measuring ranges (standard)

Nominal size	kg/h
DN 25	0 (1)... 60
DN 50	0 (10)... 400
DN 80	0 (20)... 720
DN 100	0 (40)...1200
DN 150	0 (80)...2400
DN 200	0 (200)...4000

The value in brackets specifies the lower limit of the measuring range for which the given accuracy is achieved.

Output

Output signals

Analog

0... 10 V,	(< 4 mA)
0... 20 mA,	(load < 500 Ω)
4... 20 mA,	(load < 500 Ω)

Digital output

serial V24/RS 232 C, electrically isolated
ASAM-GDI interface

Characteristics

Accuracy

Measured error (including hysteresis and non-linearity)

< ± 1 % of measured value

Repeatability: < ± 0.25 % of measured value

Influences

Temperature effect

< 0.03 %/K of measured value

Pressure effect

≤ 0.2 %/100 kPa (/bar) of measured value

Response time: $T_{63} \approx 12$ ms

Pressure drop transducer/measuring tube

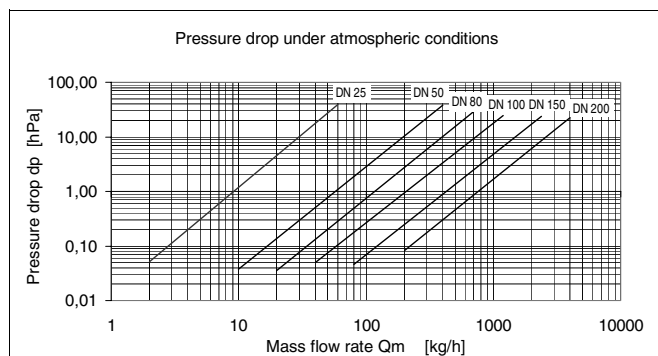

Operating conditions

Recommended steadying length

Inlet run

10 × pipe diameter (use of air filter or flow conditioner strongly recommended)

Outlet run

5 × pipe diameter

Environmental conditions

Ambient temperature for transducer

-25...+80 °C

Ambient temperature for evaluation unit

-25...+50 °C

Storage temperature

-25...+85 °C

Degree of protection

IP 54 (transducer)

Measured medium conditions

Operating temperature Medium

-25...+80 °C

Operating pressure

Standard: 0.6...2.5 × 10² kPa (2.5 bar abs.)
Option: up to 0.6...8 × 10² kPa (8 bar abs.) only DN 25

Construction

Weight

Transducer/measuring tube
depending on nominal size, see ordering information

Evaluation unit

19" plug-in version	7.0 kg
1/2 19" desktop housing	7.3 kg

Material

Transducer: aluminium, black anodized
Steadying lengths: aluminium, black anodized or glass fibre, black coated

Process connection

Quick-clamping pipe flange, aluminium
with quick-clamp chains / rings

Electrical connection

Transducer: special connecting cable
to evaluation unit

Power supply

Power supply/evaluation unit, voltage:

230 V AC
110 V AC

Power consumption evaluation unit

38 W

Power consumption transducer

10 W

Current drain transducer

< 600 mA

Dimensional drawings (dimensions in mm)

Sensyflow P NW 25

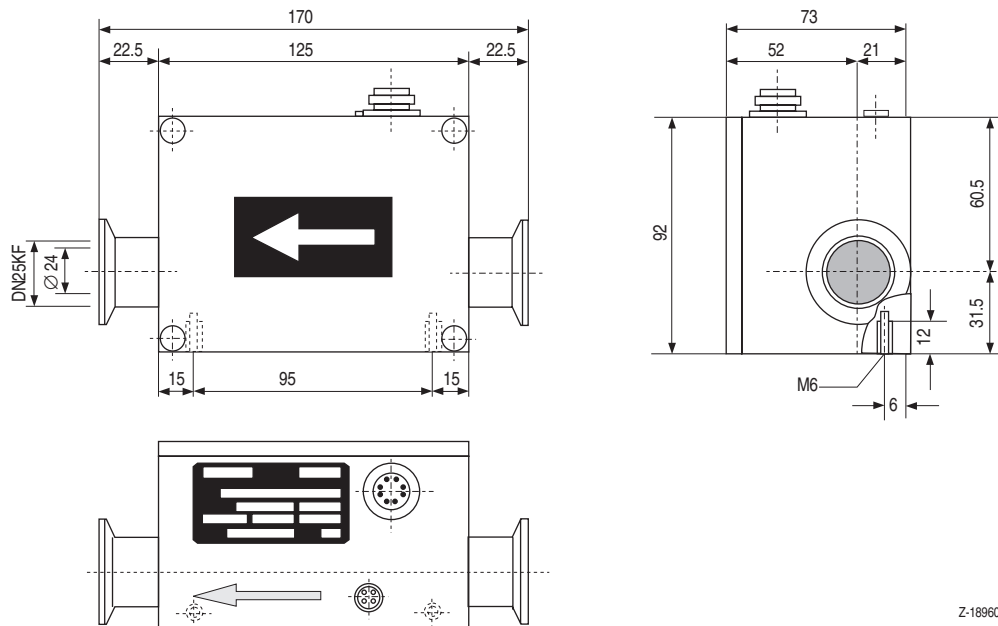

Z-18960

Sensyflow P NW 50 ... NW 200

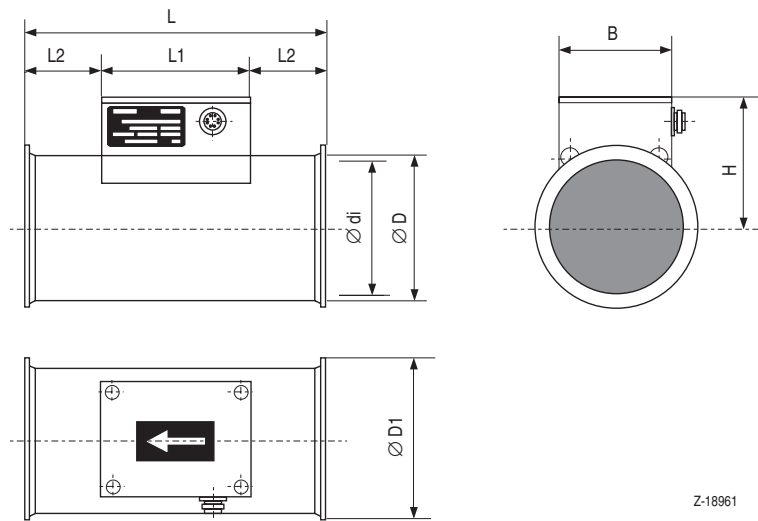

Z-18961

DN	Ø D	Ø D ₁	Ø di	L	L ₁	L ₂	B	H
50	64	80,0	58	180	125	27,5	92	85,0
80	89	108,5	80	185		30,0		93,5
100	118	132,5	109	250		62,5		108,0
150	165	180,0	153	280		77,5		131,5
200	220	240,0	200	330		102,5		159,0

Dimensions in mm

Dimensional drawings (dimensions in mm)

19" plug-in version

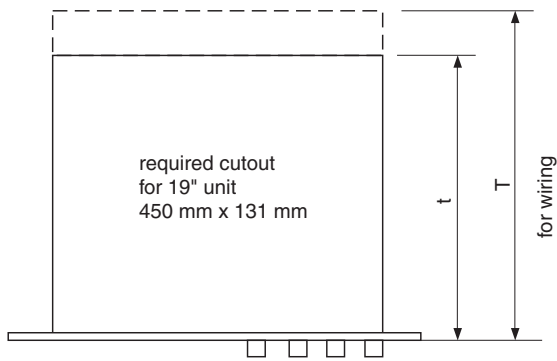
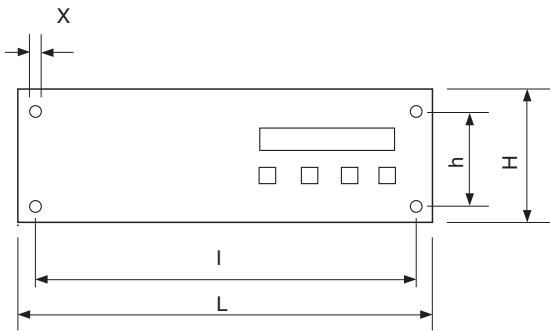

½" 19" desktop housing

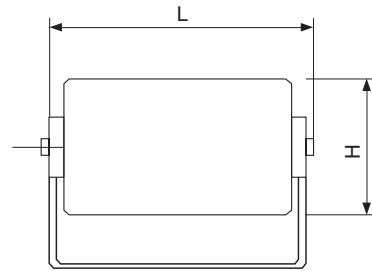

Z-17384

Unit	Dimensions	L	l	H	h	T	t	X
½ 19" desktop housing		310	/	140	/	/	/	/
19" plug-in version		483	462	132	58	425	325	M6

Dimensions in mm

Dimensional drawings (dimensions in mm)

Modules DN 25

KF = Small flange

① Filter with flange

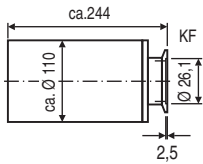

② 10 x D inlet tube with flanges (on both sides)

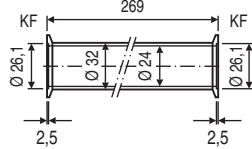

③ 5 x D outlet tube with flanges (on both sides)

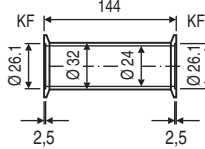

⑥ Hose adapter with flange (on one side)

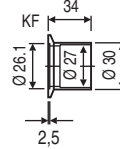

④ 10 x D inlet tube with flange (on one side)

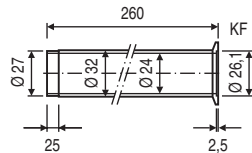

⑤ 5 x D outlet tube with flange (on one side)

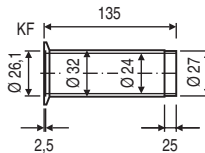

⑫ O-ring



⑬ Clamping ring FL-special

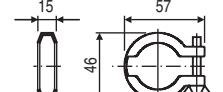

⑪ Inner-center ring



⑭ Clamping ring FL-Optimal AS

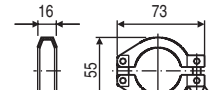

⑥ ⑪ ⑥ sectional detail pipe connection (without clamping ring)

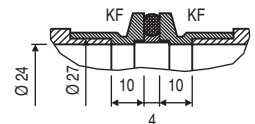

Standard measuring sections

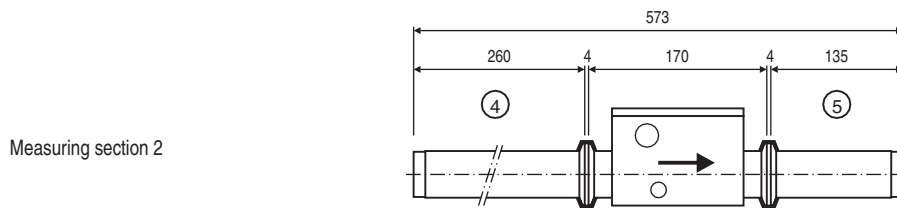
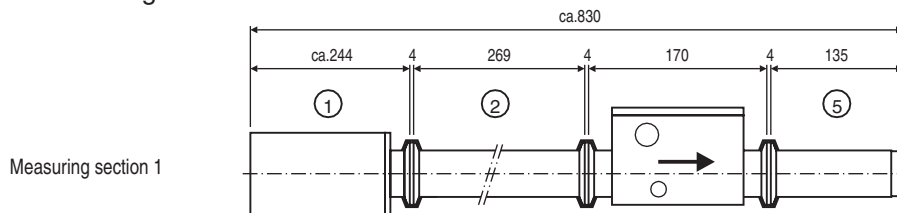

Individual planning

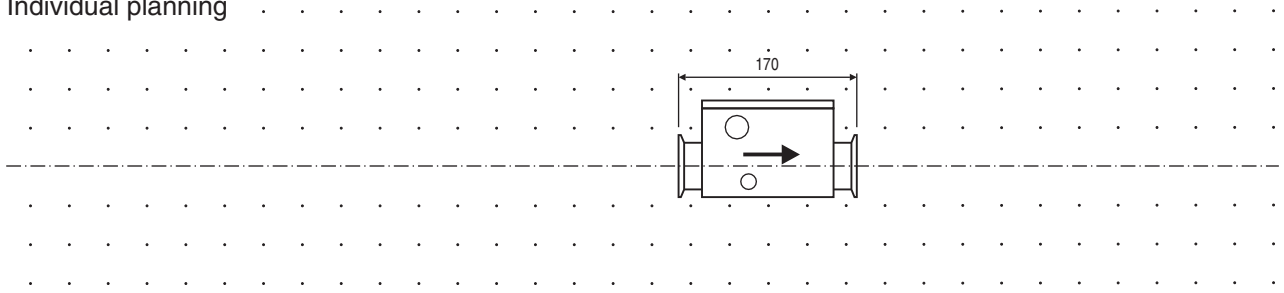

Dimensional drawings (dimensions in mm)

Modules DN 50

KOF = Tapered flange (with recessed face and groove for O-ring)
ZWF = Intermediate flange (with raised face)

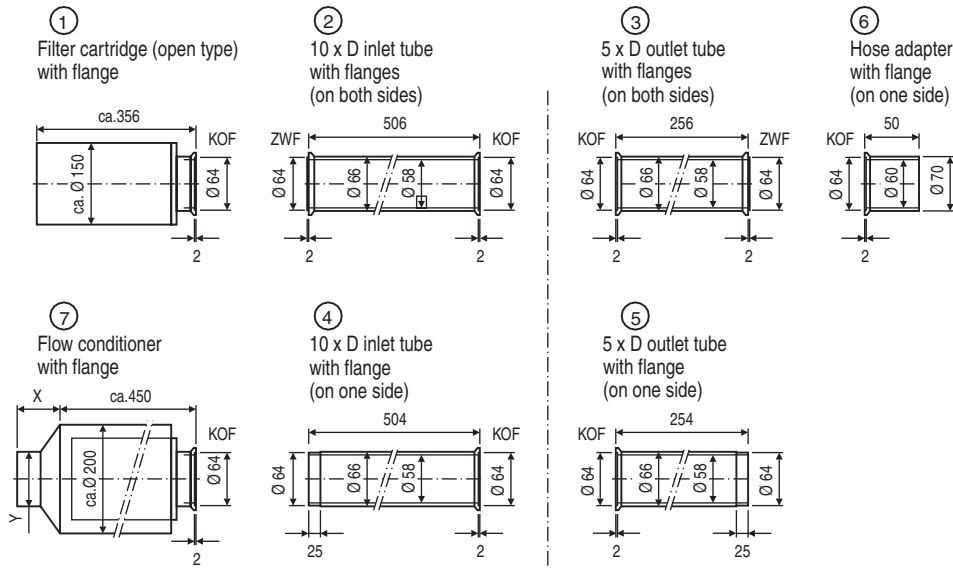

Dimensions X and Y depend on customer requirement

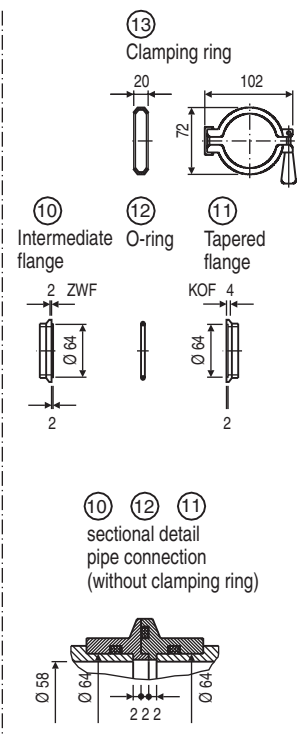

10 12 11
sectional detail
pipe connection
(without clamping ring)

Standard measuring sections

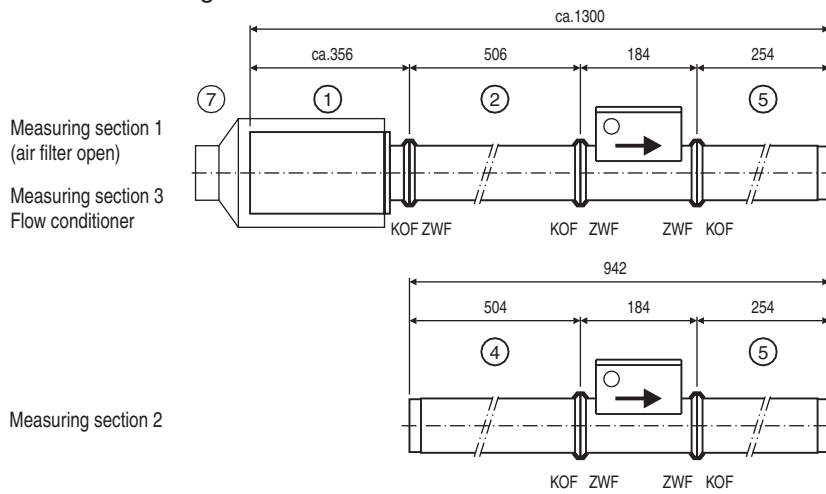

Individual planning

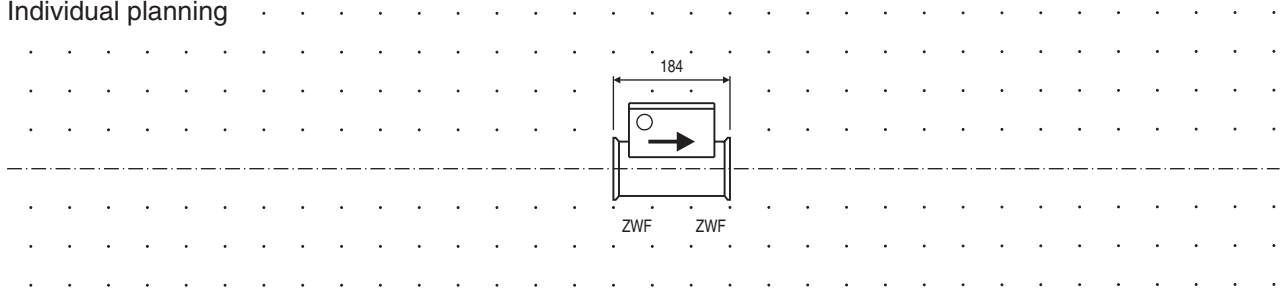

Dimensional drawings (dimensions in mm)

Modules DN 80

KOF = Tapered flange (with recessed face and groove for O-ring)
ZWF = Intermediate flange (with raised face)

① Filter cartridge (open type) with flange

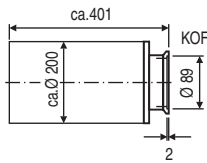

② 10 x D inlet tube with flanges (on both sides)

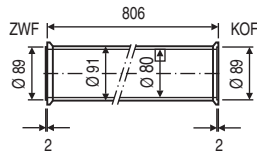

③ 5 x D outlet tube with flanges (on both sides)

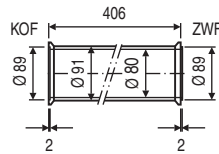

⑥ Hose adapter with flange (on one side)

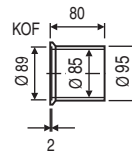

⑩ Intermediate flange

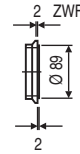

⑬ Clamping ring

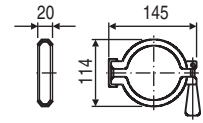

⑫ O-ring



⑪ Tapered flange

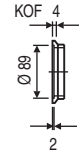

⑦ Flow conditioner with flange

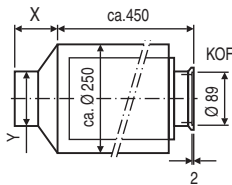

④ 10 x D inlet tube with flange (on one side)

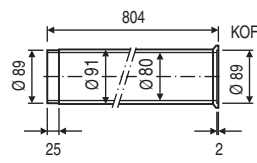

⑤ 5 x D outlet tube with flange (on one side)

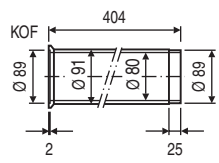

⑩ ⑫ ⑪

sectional detail pipe connection (without clamping ring)

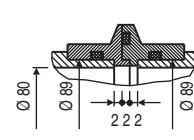

Dimensions X and Y depend on customer requirement

Standard measuring sections

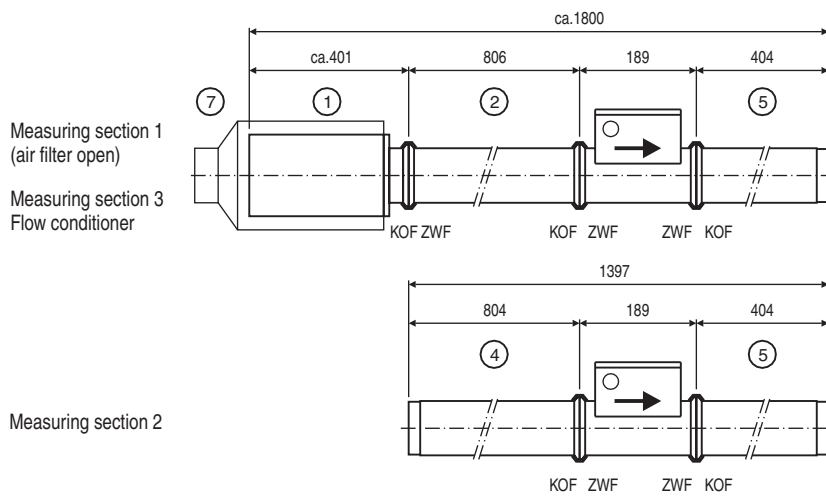

Individual planning

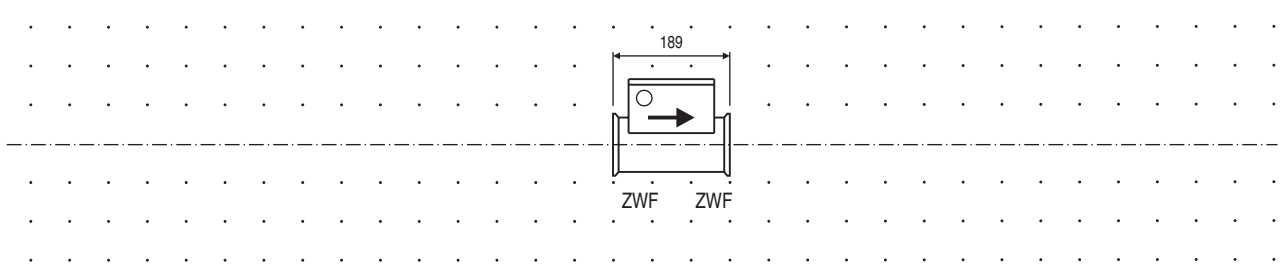

Dimensional drawings (dimensions in mm)

Modules DN 100

KOF = Tapered flange (with recessed face and groove for O-ring)
ZWF = Intermediate flange (with raised face)

① Filter cartridge (open type) with flange

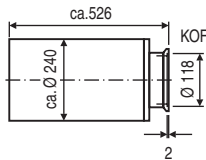

② 10 x D inlet tube with flanges (on both sides)

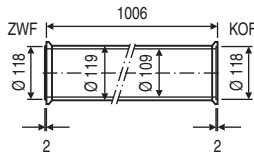

③ 5 x D outlet tube with flanges (on both sides)

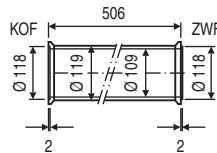

⑥ Hose adapter with flange (on one side)

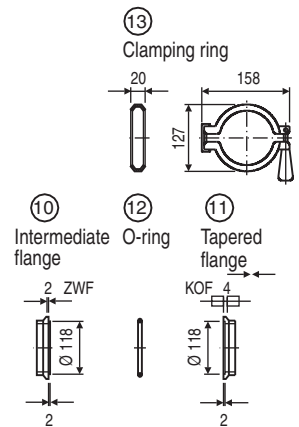
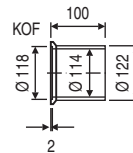

⑦ Flow conditioner with flange

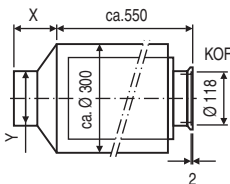

④ 10 x D inlet tube with flange (on one side)

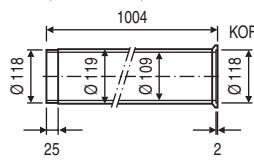

⑤ 5 x D outlet tube with flange (on one side)

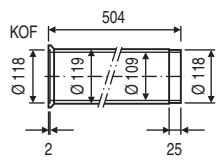

⑩ ⑫ ⑪ sectional detail pipe connection (without clamping ring)

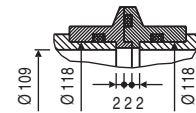

Dimensions X and Y depend on customer requirement

Standard measuring sections

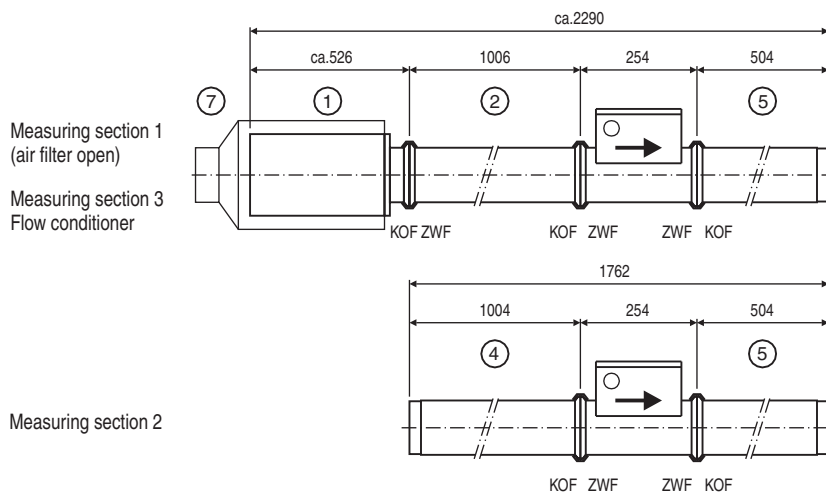

Individual planning

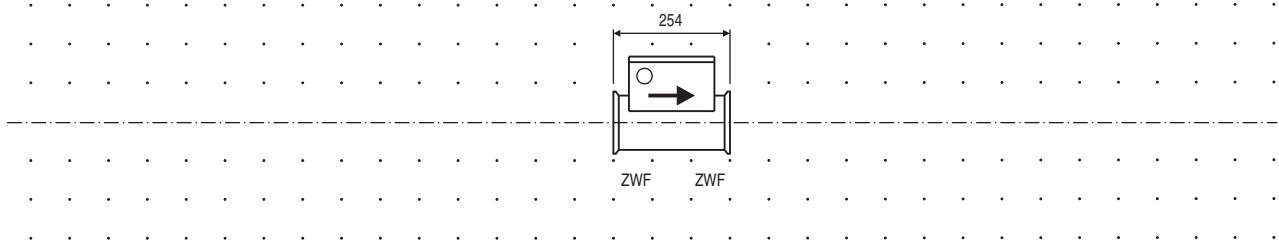

Dimensional drawings (dimensions in mm)

Modules DN 150

KOF = Tapered flange (with recessed face and groove for O-ring)
ZWF = Intermediate flange (with raised face)

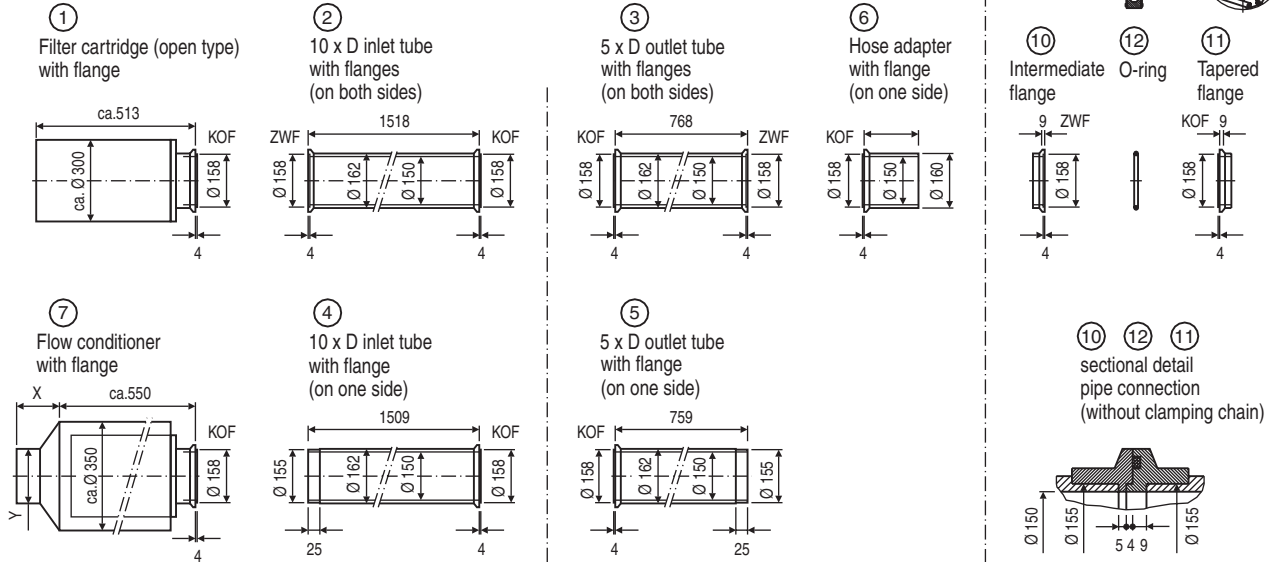

Dimensions X and Y depend on customer requirement

Standard measuring sections

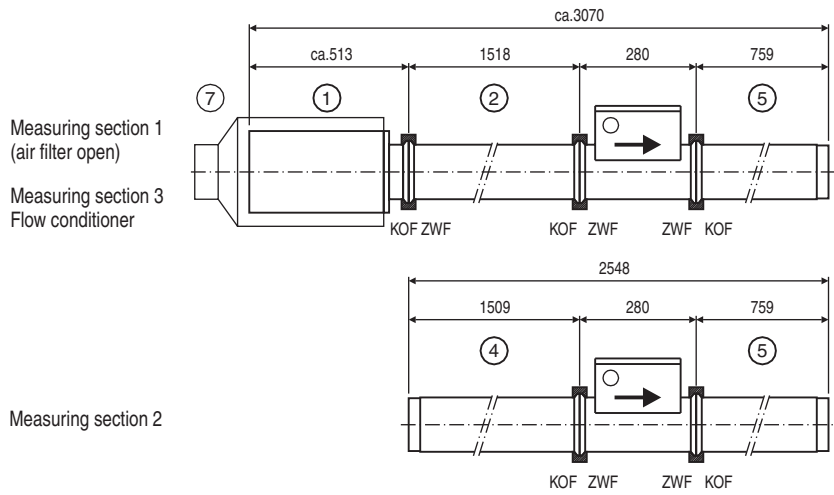

Individual planning

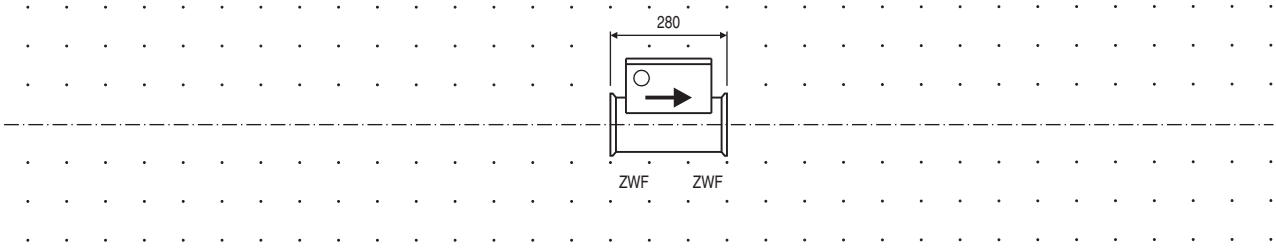

for air, test benches

Dimensional drawings (dimensions in mm)

Modules DN 200

KOF = Tapered flange (with recessed face and groove for O-ring)
 ZWF = Intermediate flange (with raised face)

① Filter cartridge (open type) with flange

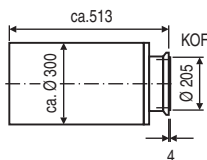

② 10 x D inlet tube with flanges (on both sides)

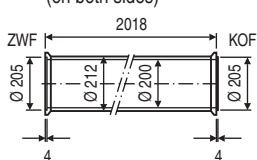

③ 5 x D outlet tube with flanges (on both sides)

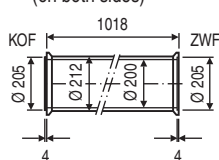

⑥ Hose adapter with flange (on one side)

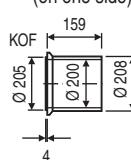

⑩ Intermediate flange

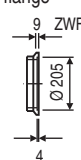

⑬ Clamping chain

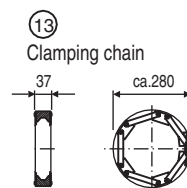

⑪ Tapered flange

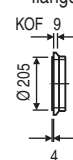

⑦ Flow conditioner with flange

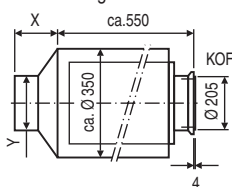

④ 10 x D inlet tube with flange (on one side)

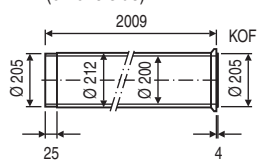

⑤ 5 x D outlet tube with flange (on one side)

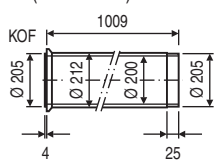

⑩ ⑫ ⑪ sectional detail pipe connection (without clamping chain)

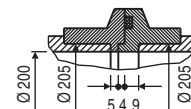

Dimensions X and Y depend on customer requirement

Standard measuring sections

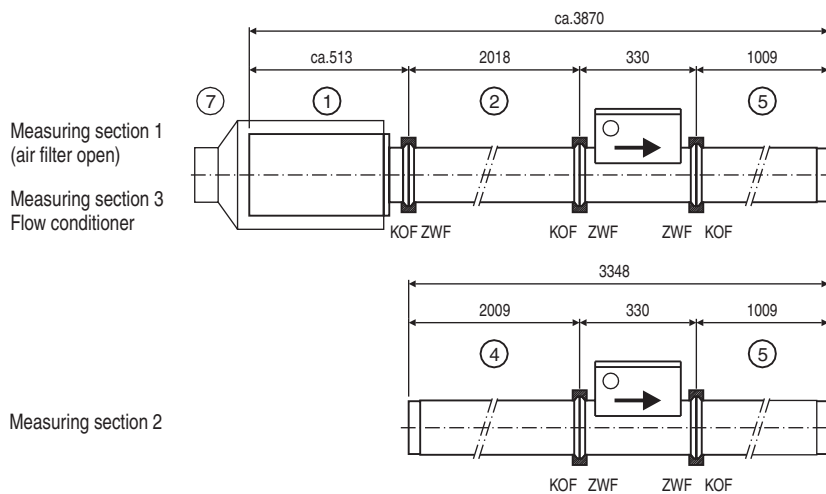

Individual planning

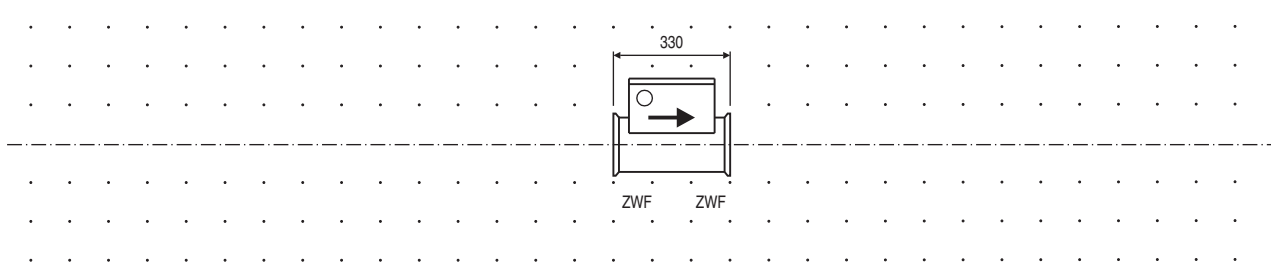

Ordering information

	Catalog No.	Code		
Transducer FMT700-P				
Comprising of: Sensor unit (built-in), transmitter circuit in terminal box including calibration				
Transducer, standard characteristic curve and calibration certificate				
Measuring-point parameters: Type of gas: air Operating temperature: -25...80 °C, Pressure (absolute): 0,6..2.5 bar				
Measuring pipe	Measuring range	Weight		
NW 25	0 (1)... 60 kg/h	1.100	7962633	
NW 50	0 (10)... 400 kg/h	2.000	7962634	
NW 80	0 (20)... 720 kg/h	2.300	7962635	
NW 100	0 (40)...1200 kg/h	3.100	7962636	
NW 150	0 (80)...2400 kg/h	4.300	7962637	
NW 200	0 (200)...4000 kg/h	7.900	7962638	
Transducer, special characteristic curve and calibration certificate 1)				
Measuring-point parameters: Type of gas: air				
Measuring pipe		Weight (kg)		
NW 25		1.100	7962639	
NW 50		2.000	7962640	
NW 80		2.300	7962641	
NW 100		3.100	7962642	
NW 150		4.300	7962643	
NW 200		7.900	7962644	
Additional ordering information				
			Code	
Definition of special characteristic				
Operating temperature (please specify with clear text)			512	
Operating pressure (please specify with clear text)			513	
Measuring range (please specify with clear text)			514	
Unit (please specify with clear text)			515	
Standard state (please specify with clear text) 2)			516	
DKD certificate			310	
In house calibration with air. DKD = Deutscher Kalibrierdienst (German calibration service), supervised by PTB (Physical and Technical Federal Institute)				
Ordering information for equipment packages 3)				
			Catalog No.	Code
Supply/evaluation unit for 1 transducer				
19" Plug-in version		Weight 7.0 kg	7964113	
Display 6 digit, display unit kg/h Power supply 230 V AC Measuring rate adjustable Serial interface V24/RS 232C, analog output 0...10 V Temperature display				
1/2 19" Desktop housing		Weight 7.3 kg	7964114	
Display 6 digit, display unit kg/h Power supply 230 V AC Measuring rate adjustable Serial interface V24/RS 232C, analog output 0...10 V Temperature display				

1) Definition of the special characteristic curve, see additional ordering information

2) e. g. Nm3/h related to standard conditions 0 °C, 1013 mbar (hPa)

3) 10 % discount in relation to individual combination

for air, test benches

Ordering information

		Catalog No.						Code		
Supply/evaluation unit FMT700-P		V14243-					0			
Supply/evaluation unit Display 6 digit, display unit kg/h, measuring rate adjustable for 1 transducer for 2 transducers		1 2								
Design	weight (kg)									
19" Plug-in card	7.0	1								
1/2 19" Desk-top housing	7.3	2								
2nd Display unit see Code Nos 401-409										
Temperature display see Code Nos 411, 412										
Power supply 230 V AC 110 V AC		1 2								
Digital interface without V24/RS 232 C, serial ASAM-GDI and V24/RS 232 C, serial			0 1 2							
Totalizer without Totalizer, only in combination with V24/RS 232 C interface			0 1							
Output signal 0...10 V 0...10 V and 0...20 mA 0...10 V and 4...20 mA						1 4 5				
Additional ordering information										
								Code		
Details only with subsequent or individual order for special characteristic curves or standard volume unit										
Measuring-point parameter, type of gas air										
Operating temperature (please specify in clear text)								512		
Operating pressure (please specify in clear text)								513		
Measuring range (please specify in clear text)								514		
Unit (please specify in clear text)								515		
Standard state (please specify in clear text)								516		
2nd display unit, switchable to:										
g/s								401		
Nm³/h (at 0 °C and 1013 hPa)								402		
Nm³/h (at 20 °C and 1013 hPa)								403		
Nl/s (at 0 °C and 1013 hPa)								404		
Nl/s (at 20 °C and 1013 hPa)								405		
Nl/min (at 0 °C and 1013 hPa)								406		
Switchable to (please note Code-No 516), please specify with clear text								409		
Temperature display										
for 1 transducer								411		
for 2 transducers								412		
Accessories										
								Catalog No.		
Supply/evaluation unit, later implementation of ASAM-GDI including certification (only in combin. with serial interface)								7962840		

Ordering information accessories

	Catalog No.	Code		
Measuring section 1 , comprising of:				
Air filter (open), inlet tube 10 x D, 1 tapered flange, 1 intermediate flange, outlet tube 5 x D, 1 tapered flange, 3 clamping rings/chains				
Nominal size	Weight (kg)			
NW 25	1.500	7962645		
NW 50	4.100	7962646		
NW 80	8.250	7962647		
NW 100	12.600	7962648		
NW 150	20.000	7962649		
NW 200	25.600	7962650		
Measuring section 2 , comprising of:				
Inlet tube 10 x D, 1 tapered flange, outlet tube 5 x D, 1 tapered flange, 2 clamping rings/chains				
Nominal size	Weight (kg)			
NW 25	0.530	7962651		
NW 50	2.030	7962652		
NW 80	5.100	7962653		
NW 100	7.600	7962654		
NW 150	12.000	7962655		
NW 200	16.800	7962656		
Measuring section 3 , comprising of:				
Flow conditioner, inlet tube 10 x D, 1 tapered flange, 1 intermediate flange, outlet tube 5 x D, 1 tapered flange, 3 clamping rings/chains, hose socket on suction side				
Nominal size	suction side	Weight (kg)		
NW 50	NW 80	9.600	7964108	
NW 80	NW 100	13.900	7964109	
NW 100	NW 150	21.200	7964110	
NW 150	NW 200	32.000	7964111	
NW 200	NW 250	39.000	7964112	
Air filter (open) ① , Filter coupling flange, 1 clamping ring/chain 4)				
Nominal size	Weight (kg)			
NW 25	0.900	7962657		
NW 50	1.980	7962658		
NW 80	3.100	7962659		
NW 100	4.930	7962660		
NW 150	7.500	7962661		
NW 200	8.100	7962662		
Flow conditioner ⑦ , Filter coupling flange, 1 clamping ring/chain, hose socket on suction side 4)				
Nominal size	suction side	Weight (kg)		
NW 50	NW 80	7.500	7964102	
NW 80	NW 100	8.700	7964103	
NW 100	NW 150	13.500	7964104	
NW 150	NW 200	19.500	7964105	
NW 200	NW 250	21.500	7964106	
Inlet tube 10 x D ② , 1 Tapered flange, 1 intermediate flange, 1 clamp. ring/chain 4)				
Nominal size	Weight (kg)			
NW 25	0.350	7962663		
NW 50	1.380	7962664		
NW 80	3.300	7962665		
NW 100	5.000	7962666		
NW 150	8.200	7962667		
NW 200	11.400	7962668		

4) See dimensional drawings, Data Sheet

Ordering information accessories

	Catalog No.	Code		
Inlet tube 10 x D ④ , 1 Tapered flange, 1 clamping ring/chain 4)				
Nominal size Weight (kg)				
NW 25 0.320	7962669			
NW 50 1.300	7962670			
NW 80 3.200	7962671			
NW 100 4.900	7962672			
NW 150 7.900	7962673			
NW 200 10.700	7962674			
Outlet tube 5 x D ③ , 1 Tapered flange, 1 intermediate flange, 1 clamp. ring/chain 4)				
Nominal size Weight (kg)				
NW 25 0.320	7962675			
NW 50 0.800	7962676			
NW 80 1.850	7962677			
NW 100 2.800	7962678			
NW 150 4.600	7962679			
NW 200 6.700	7962680			
Outlet tube 5 x D ⑤ , 1 tapered flange, 1 clamping ring/chain 4)				
Nominal size Weight (kg)				
NW 25 0.250	7962681			
NW 50 0.750	7962682			
NW 80 1.750	7962683			
NW 100 2.700	7962684			
NW 150 4.300	7962685			
NW 200 6.100	7962686			
Hose adapter ⑥ , 1 tapered flange, 1 clamping ring/chain 4)				
Nominal size Weight (kg)				
NW 25 0.120	7962687			
NW 50 0.320	7962688			
NW 80 0.500	7962689			
NW 100 0.630	7962690			
NW 150 1.600	7962691			
NW 200 2.000	7962692			
Ordering information individual parts				
	Catalog No.	Code		
Tapered flange ⑪ (please order O-ring separately) 4)				
Nominal size Weight (kg)				
NW 25 0.020	7962700			
NW 50 0.067	7962701			
NW 80 0.112	7962702			
NW 100 0.114	7962703			
NW 150 0.353	7962704			
NW 200 0.600	7962705			
O-Ring ⑫ (DN 25 includes centering rings) 4)				
Nominal size Weight (kg)				
NW 25 0.012	7962706			
NW 50 0.004	7962707			
NW 80 0.005	7962708			
NW 100 0.006	7962709			
NW 150 0.015	7962710			
NW 200 0.031	7962711			

4) See dimensional drawings, Data Sheet

Ordering information individual parts

	Catalog No.	Code		
Intermediate flange ⑩	4)			
Nominal size Weight (kg)				
NW 25 0.020	7962712			
NW 50 0.068	7962713			
NW 80 0.102	7962714			
NW 100 0.111	7962715			
NW 150 0.214	7962716			
NW 200 0.610	7962717			
Clamping ring ⑬	4)			
Nominal size Weight (kg)				
NW 25 0.087	7962718			
NW 50 0.180	7962719			
NW 80 0.180	7962720			
NW 100 0.230	7962721			
Clamping chain ⑬	4)			
Nominal size Weight (kg)				
NW 150 0.590	7962722			
NW 200 0.720	7962723			
Complete flange coupling , comprising of: 1 tapered flange, 1 intermediate flange, O-ring and 1 clamping ring/chain				
Nominal size Weight (kg)				
NW 25 0.137	7962724			
NW 50 0.320	7962725			
NW 80 0.430	7962726			
NW 100 0.480	7962727			
NW 150 1.210	7962728			
NW 200 2.020	7962729			
Filter cartridge				
Nominal size Weight (kg)				
NW 25 0.630	7962730			
NW 50 1.400	7962731			
NW 80 2.250	7962732			
NW 100 4.000	7962733			
NW 150 5.000	7962734			
NW 200 5.000	7962735			
Filter coupling flange				
Nominal size Weight (kg)				
NW 25 0.198	7962736			
NW 50 0.420	7962737			
NW 80 0.670	7962738			
NW 100 0.740	7962739			
NW 150 1.900	7962740			
NW 200 2.450	7962741			
Transducer cables				
Length Weight (kg)				
3 m 0.220	7962693			
8 m 0.490	7962694			
15 m 0.860	7962695			
30 m 2.560	7962696			
Interface cable				
25-pin connector (1 piece), length 3 m, weight 0.220 kg	7962697			

4) See dimensional drawings, Data Sheet

ABB has Sales & Customer Support expertise in over 100 countries worldwide.

www.abb.com

The Company's policy is one of continuous product improvement and the right is reserved to modify the information contained herein without notice.

Printed in the Fed. Rep. of Germany (11.04)

© ABB 2004



ABB Ltd.
Oldends Lane, Stonehouse
Gloucestershire, GL10 3TA
UK
Tel: +44(0)1453 826661
Fax: +44(0)1453 827856

ABB Inc.
125 E. County Line Road
Warminster, PA 18974
USA
Tel: +1 215 674 6000
Fax: +1 215 674 7183

ABB Inc.
3450 Harvester Road
Burlington Ontario L7N 3W5
Canada
Tel: +1 905 681 0565
Fax: +1 905 681 2810

ABB Automation Products GmbH
Borsigstr. 2
63755 Alzenau
Germany
Tel: +49 551 905-534
Fax: +49 551 905-555
CCC-support.deapr@de.abb.com